



# Footrot

A guide to identification and control in the field

[www.sheepconnecttas.com.au](http://www.sheepconnecttas.com.au)



# Contents

1. Overview .....	4	7. Eradication inspections.....	42
2. Identifying footrot in the field .....	8	8. Treatment .....	46
3. Laboratory diagnosis .....	18	9. Footbath design and construction....	54
4. Taking a sample .....	21	10. Surveillance and prevention.....	62
5. Eradication .....	30	Glossary .....	66
6. Specific vaccines .....	38		

Published by Australian Wool Innovation Ltd.  
Date of publication January 2016

This publication should only be used as a general aid and is not a substitute for specific advice. To the extent permitted by law, we exclude all liability for loss or damage arising from the use of the information in this publication.

© 2015 Australian Wool Innovation Ltd. All rights reserved. Australian Wool Innovation Ltd gratefully acknowledges the funds provided by the Australian government to support research, development and marketing of Australian wool.

**For further information:**

Contact your veterinary practitioner or State Departmental Veterinary Officer.

Sheep Connect Tasmania: [www.sheepconnecttas.com.au](http://www.sheepconnecttas.com.au)



# Introduction

Footrot is a serious and highly-contagious disease of sheep and goats spread by the *Dichelobacter nodosus* bacterium.

Virulent footrot has significant welfare and economic impacts in both individual sheep enterprises and the national flock as a whole. While the number of flocks with virulent (severe) strains of footrot has been reduced considerably during the past 20 years, footrot remains a serious disease.

This publication has been developed as part of a collaborative project between the Department of Primary Industries, Parks, Water and Environment (DPIPWE) Tasmania and Sheep Connect Tasmania, with funding from Australian Wool Innovation (AWI). The purpose of this publication is to encourage best-practice footrot diagnosis, control and eradication, with the objective of building a sustainable Australian wool industry through improvements in productivity and profitability.

Better diagnosis and control of footrot should result in:

- healthier, more productive sheep
- easier trading between flocks
- lower treatment and labour costs
- increased confidence in state-based control programs.

## About Sheep Connect Tasmania

Sheep Connect Tasmania is an extension and communication project aimed at increasing the productivity, confidence and resilience of Tasmanian sheep and wool businesses, and enhancing the industry's reputation of being profitable and sustainable.

Its objectives are to:

- continue to be recognised as the key conduit for valuable, relevant and timely farming systems information, enabling sheep and wool producers to improve their businesses;
- proactively identify Tasmanian sheep and wool industry priorities;
- maintain flexibility to manage arising opportunities and challenges;
- help producers acquire the skills to effectively integrate sheep and wool into an evolving farming system; and
- actively promote opportunities for younger sheep and wool producers.



# Overview

## Key messages

- Footrot is a serious and highly-contagious disease of sheep and goats spread by the *Dichelobacter nodosus* bacterium.
- Under suitable environmental conditions (moist and warm) virulent strains of the *D. nodosus* bacteria can penetrate and infect the skin between the toes leading to severe pain and lameness.
- Discharge from the feet of infected animals spreads to the feet of previously unaffected animals via moist, infected pasture, muddy yards and laneways.
- Footrot has significant impacts on enterprise productivity and profitability, as well as animal and human welfare.
- The key to management is early detection and treatment.

**NOTE:** See **Section 2. Identifying footrot in the field** for further details on how to diagnose footrot and differentiate it from other conditions causing lameness in sheep.

## What is footrot?

Virulent footrot is a serious and highly-contagious bacterial disease, which affects the feet of sheep and goats.

The first sign of infection is a reddening of the skin between the toes. This can rapidly develop and spread to cause under-running and separation of the hard horn of the hoof from the sensitive soft tissue underneath, resulting in severe pain and lameness. The disease can progress from reddened skin to severe under-running in 10–14 days.

Virulent footrot is an important condition due to its economic impacts on farming enterprises and animal and human welfare implications.

## How is footrot spread?

Footrot is caused and spread by the bacterium *Dichelobacter nodosus*. The *D. nodosus* bacteria thrives in moist mild conditions. Although footrot can occur throughout Australia, it is most common in medium to high rainfall areas.

There are many strains (or types) of *D. nodosus*, which vary in their ability to cause disease from mild *benign* to extremely *virulent*. Benign types (also known as 'scald') usually only affect the skin between the toes regardless of the environmental conditions. Virulent types often cause severe under-running (except in goats) and spread rapidly in warm moist conditions. Intermediate types fall in between.

Disease outbreaks usually occur when the average daily temperature is above 10 degrees Celsius, so spread does not usually occur during very cold winters, but mostly during mild wet winters, autumn and spring. Footrot will not spread under hot dry conditions — 125mm of rain per month is generally required for footrot to spread during summer.

While the bacterium cannot usually survive for longer than seven days in soil and dies quickly in dry conditions, it can survive for years in the feet of infected animals, even if environmental conditions are hostile.

The ability of the soil type to retain moisture and the pasture type, both play a role in disease spread and expression. Footrot is commonly associated with lush, improved or irrigated pastures but can occur on any long, dense, persistently moist pasture.

Prolonged wet conditions underfoot often cause damage to the skin between the toes (interdigital skin), allowing bacteria to establish in the damaged tissue. Post-harvest crop stubble and long pasture species also can damage the interdigital skin, favouring footrot infection.



**Insidious infection:** Footrot is a highly-contagious bacterial disease which infects the feet of sheep and goats, causing severe pain and lameness.

Discharge from the feet of infected animals is the main source of infection by contaminating pastures and yards. Bacteria in the discharge spreads from the feet of infected animals to those of previously unaffected animals via moist, contaminated pasture, muddy yards and laneways.

Goats, deer and cattle also can carry and spread the bacteria, although surveys of fallow deer in Tasmania have failed to detect footrot, and cattle almost always only carry benign footrot.

Goats are susceptible to footrot in the same way as sheep, and disease spread, symptoms, impacts and treatment are similar.

# Overview

## Animal susceptibility

Some sheep breeds are more susceptible to footrot than others and even within one breed of sheep some individuals are more resistant than others. Merinos generally tend to be more susceptible to footrot than British breeds of sheep, such as Dorset and Border Leicester.

Footrot can occur in sheep of all ages. Generally the severity of lesions in ewes increases with age and older lambs have more severe lesions than younger ones.

Prior natural infection does not provide immunity to subsequent challenges.

A large proportion of a mob can be affected within one to two weeks of exposure to the bacteria. Spread within a mob is assisted by the natural flocking instinct of sheep, particularly when there is heavy contamination around common feeding and drinking areas.

Both claws of a foot and often more than one foot on the sheep will be affected.

Sheep with apparently healthy looking feet may still carry a virulent strain of footrot if conditions at the time are not favourable for the bacteria's development. Infection may only become apparent when environmental conditions become warm and moist or careful diagnostic paring is carried out.

## Economic and welfare impacts

Footrot can have a major impact on flock productivity and profitability. Lameness and pain in affected animals reduces their mobility and ability to graze efficiently. This results in poorer growth rates, longer finishing times, higher mortality rates, reduced wool production and quality (fibre diameter and tensile strength are affected) and lower ewe fertility.

### Foot note



Lambing percentages and fleece weights are estimated to be reduced by 10% in sheep with at least one severely affected foot. The greater the severity of footrot in a flock, the greater the impact on productivity and profitability.

Footrot can also be a major animal welfare issue for sheep. Infection and erosion of the sensitive tissue in the feet can cause extreme pain. In severe cases the hard horn of the hoof may slough off.

Often infected animals cannot bear weight on affected feet and if more than one foot is affected they may be unable to stand. Affected sheep limp, carry the affected leg and may graze on their knees. Animals unable to walk and graze for long enough become emaciated and can starve to death.

## Associated impacts

The discharge associated with footrot attracts flies, so many footrot-affected sheep suffer flystrike of infected feet, resulting in additional pain. When the front feet are affected this can lead to body strike if the sheep lies down with the infected front foot resting against its side.

Footrot-affected ewes are also more predisposed to developing pregnancy toxæmia during late pregnancy, which may lead to the death of both the ewe and her offspring.

In addition to direct losses of production and profit, additional economic impacts occur through the need for repeat yardings of sheep and disruption to farm routine together with the expense of labour and materials to treat the disease.

Market access is also affected: infected sheep cannot be sold through a saleyard — they may be sold for slaughter only, and some overseas markets will only buy sheep from flocks certified as 'footrot free'.

### Foot note



Footrot is a serious disease of sheep. For more information on preventing, diagnosing and treating footrot contact your local veterinarian or animal health advisor.

New South Wales, South Australia and Western Australia have state footrot control programs. In these states when footrot is detected an inspector of livestock must be notified. The inspector has the power to restrict movement of infected or suspect sheep and ensure treatment is carried out.

Footrot also has impacts on human welfare. Footrot can be difficult to control or eradicate when established in a flock. It can be time consuming and frustrating to manage. Many farmers find the psychological, economic and welfare impacts of the disease in their flock extremely distressing.

Footrot can also sometimes affect a whole community by creating unnecessary ill-feeling and hostility between neighbours and friends as individuals are blamed for the introduction and spread of disease in a community. 🗨️

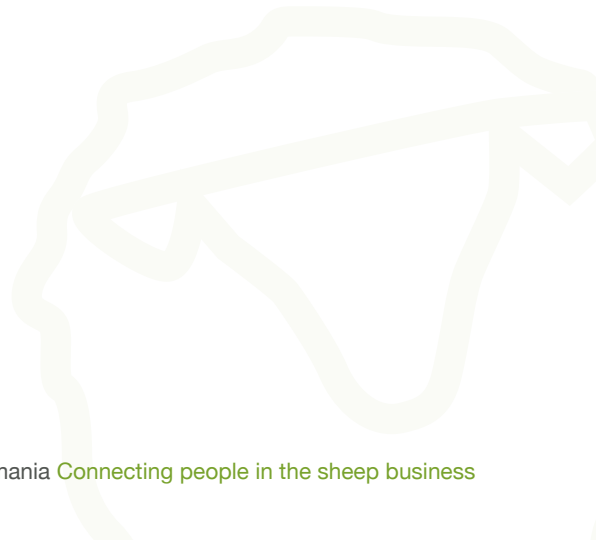

# Identifying footrot in the field

## Key messages

- Lameness is the first sign of footrot. Inspect sheep with signs of lameness promptly.
- Footrot can be difficult to diagnose and differentiate from other common foot and lower-leg diseases and conditions in sheep and goats.
- A scoring system has been developed to describe the signs and progression of footrot. Score 1 is the mildest stage of the disease through to Score 5, which is the most advanced stage.
- There are many strains (or types) of footrot bacteria (*Dichelobacter nodosus*), which vary in their ability to cause disease from mild benign to extremely virulent.
- Laboratory tests can confirm the presence of footrot and determine the virulence status of any footrot infection.

## Identifying footrot

Lameness is the first sign of footrot. Investigate any signs of lameness promptly; especially in flocks considered footrot-free. Footrot can be difficult to distinguish from other diseases and conditions of the foot and lower leg of sheep and goats.



**First signs:** Lameness is often the first sign of footrot. Inspect any lame sheep for footrot as soon as possible in order to implement a timely eradication program.



A prompt, accurate diagnosis will help to determine the best treatment program and reduce the impacts of the disease.

An initial footrot diagnosis is made by examining the foot for the presence of a lesion (wound) that is characteristic of footrot, as shown on the following pages.

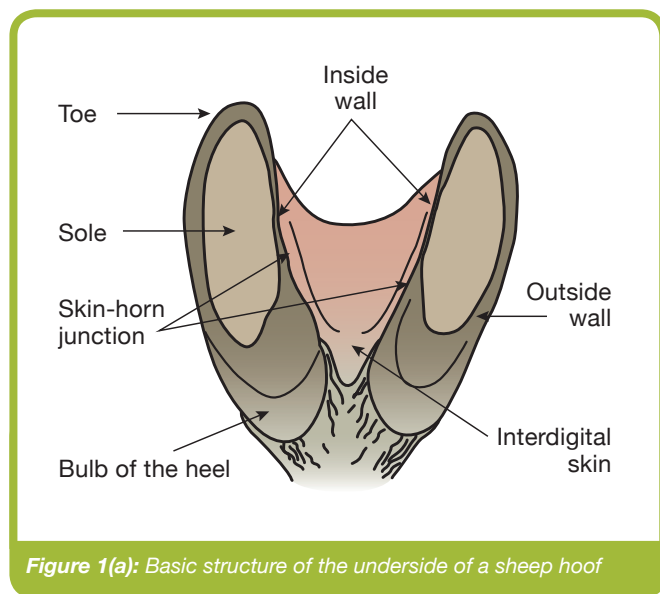

Infected feet often, but not always, have a characteristic foul smell.

The signs of footrot infection vary from mild reddening of the interdigital skin (skin between the toes) to complete separation of the hard horn of the hoof from the soft tissue underneath. Figures 1a and 1b below show the basic structure of the hoof as a reference for the descriptions of each successive stage of infection covered on the following pages.

Benign footrot usually only involves the interdigital skin, but this can also be the first stage of virulent footrot.

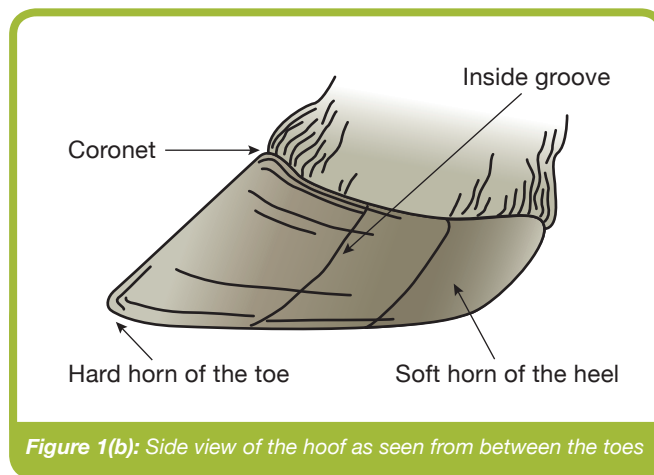

# Identifying footrot in the field

## Foot scoring

A scoring system has been developed to describe the signs and progression of footrot. Score 1 is the mildest stage of the disease through to Score 5, which is the most advanced stage.

The five stages/scores are outlined on the following pages.

### Score 1



*The infection is confined to the interdigital skin and the inflammation is only mild to moderate (this stage maybe referred to as foot scald). The surface layer of skin is reddened, moist and there is hair loss from the skin. 1. Moisture evident between toes. Early signs of exudate and hair loss (goat). 2. Hair loss between toes, reddening of skin and whitish skin in interdigital cleft. 3. Reddening of the skin, moist exudate has matted the hair between the toes. 4. Reddening of the skin, hair loss and prior episodes of scald have damaged the horn growth of the inside wall.*

### Score 2

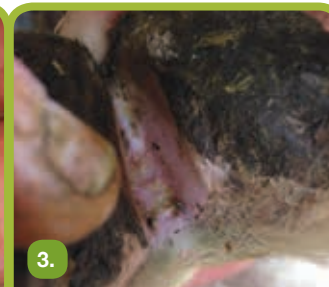

The inflammation of the interdigital skin is more severe and may involve part or all of the soft horn on the inside wall of the toe, but there is less than 2mm of under-running of the sole. **1.** Granulation of skin between the toes because of constant moisture and footrot infection. **2.** Severe interdigital inflammation, high exudate levels, loss of hair and erosion of the skin – horn junction. **3.** Complete hair loss, significant inflammation and exudate levels.

### Score 3

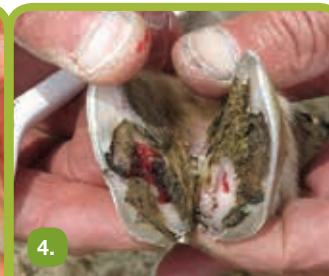

There is under-running of more than 2mm of the sole, but the under-running of the sole does not extend to the edge of hard horn of the wall in the tip of the toe area. The amount of under-running can be further scored 3a, 3b or 3c for research purposes. **1.** Under-running has only extended over the bulb of the heel. **2.** Under-running extends about half way along the sole. **3.** Under-running extends about three-quarters of the length of the sole. **4.** Under-running stops just short of the tip of the sole area.

# Identifying footrot in the field

## Score 4

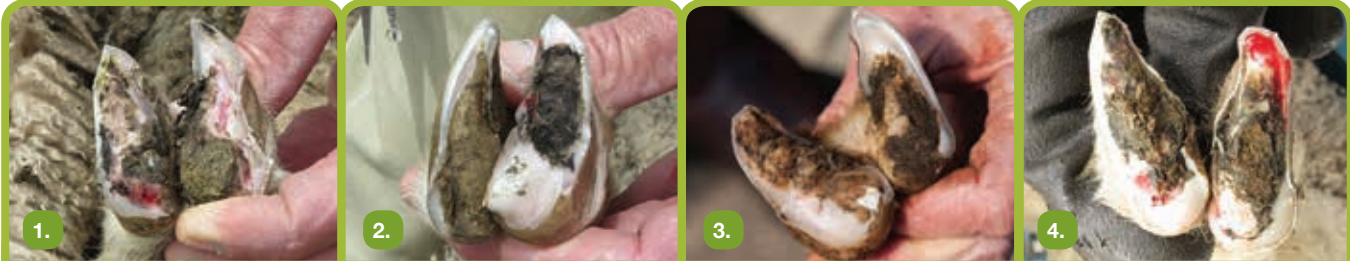

There is under-running of all of the sole right out to the wall of the hoof including the toe area. 1. Active under-running of the whole sole. 2. The heel area has healed but the front of the sole is chronically infected. 3. Chronic under-run of the sole. 4. Whole sole under-run with some areas dry, some active.

## Score 5

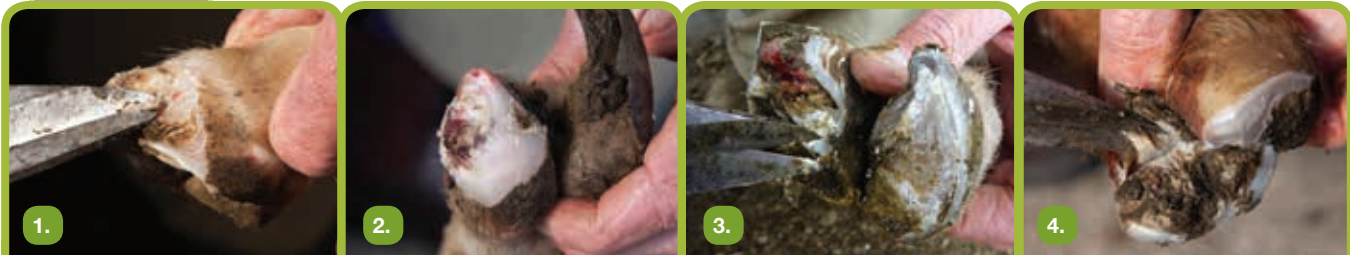

There is under-running of the hard horn of the wall of the hoof, sometimes including the hard horn flap on the inside of the toe. 1. Most of the front wall of the toe area chronically under-run. 2. The heel and side wall chronically under-run. 3. Hard horn of the toe area under-run by active infection. 4. The infection has under-run the hard horn of the inside flap of the toe.

## Other conditions

A number of conditions can easily be confused with footrot, especially when they occur under the same environmental conditions. Some of these are outlined below:

### Foot ('heel') abscess

Foot abscess is caused by *Fusobacterium necrophorum* (a bacterium that is ever present in the soil).

Foot abscess may be present in several sheep in a flock at the same time but is not contagious (usually only a small percentage of the flock is affected). It is usually seen in heavy sheep (pregnant ewes, rams), under wet paddock conditions, and is more common in the front feet.

Foot abscess develops from damage to the interdigital skin, and this damage can be seen in the very early stages as a small 'nick' in the skin penetrating into the soft tissue in the interdigital cleft next to the heel.

Foot abscess usually occurs in one digit, and usually only affects one foot.

Local heat, swelling and pain on palpation are usually observed. White or creamy pus may break out of the abscess at the coronet. The sheep may hold the affected foot off the ground.

There is no characteristic footrot odour and usually no separation of the sole; except at the point where the abscess breaks open.



**Foot abscess:** Infection is breaking out above the coronet (hoof line) showing hair loss and swelling. **INSET:** Swollen foot with infection breaking out between the toes.

# Identifying footrot in the field

## Toe abscess

Toe abscess most commonly involves front feet and results from damage to the hoof wall in the toe area. It occurs most often when conditions are wet and feet are overgrown. It can also occur as a result of shelly hoof.

Contamination enters through a crack in the hard horn, bacteria multiply and form an abscess, but the pus cannot escape through the hard horn, so it forms a track up to the coronet or back under the sole of the foot.

Toe abscess can be hard to differentiate from footrot without laboratory tests. It can appear as a red 'cherry' or proud flesh at the point of the toe after paring back under-run hard horn (although proud flesh can also be associated with overzealous foot paring).



**Toe abscess: TOP:** Typical site of infection entry at point of toe  
**BOTTOM:** Infection has progressed along the toe and broken out above the hoof.

### Ovine interdigital dermatitis

Ovine interdigital dermatitis (OID) is an inflammation (reddening) of interdigital skin, usually of more than one foot, during warm weather, particularly when the pasture is lush or muddy. This condition is also caused by *Fusobacterium necrophorum* (the causal bacteria for foot abscess).

As this bacterium is always present in the soil OID can occur whenever weather and paddock conditions are favourable.

The symptoms of OID are identical to score 1 footrot (scald), with no under-running, and can only be differentiated from footrot by taking smears on glass slides or swabs for laboratory tests.

OID heals quickly if feet are kept dry, such as overnight on the grating in the shearing shed, or with footbathing.



**Ovine interdigital dermatitis:** Laboratory tests using smear samples are the only way to get a definitive diagnosis for OID.

### Shelly toe

Shelly toe occurs when there is a natural dry separation of the outside of the hoof horn near the point of the toe. A cavity forms between the horn and the hoof and this often fills with soil and dung. The cavity is curved and symmetrical, and the wall on the hoof side of the cavity is relatively smooth. Usually both front, and sometimes both back, feet are affected.

This condition mostly affects Merino sheep, and occasionally other breeds, on improved pasture.

When paddock conditions are wet, and gravel packs into the cavity, the small stones can break through into soft tissue and allow bacteria to enter and cause toe abscess (see previous page for clinical signs of toe abscess).

If infection is not present, paring of the outer wall over the shelly area and cleaning the dung and soil out of the cavity is all the treatment required.



**Shelly toe:** Note elliptical shape of separation and relatively smooth, dry surface exposed by paring.

# Identifying footrot in the field

## Orf (scabby mouth) infection of the feet

Orf (often referred to as scabby mouth) can occur as scabs on the feet above the coronet. There is no involvement of hard or soft horn of the hoof. Some sheep in the mob will usually show classical scabby-mouth lesions.

Orf is often seen in unvaccinated young sheep grazing lush pasture, rough pasture or stubble. Orf usually self-cures in about three weeks — no treatment is required.

## Strawberry footrot (proliferative dermatitis)

Strawberry footrot is caused by *Dermatophilus congolensis*, the same bacterium that causes lumpy wool.

Scabs appear on the legs from the coronet to the knee or hock with hair loss. Scab removal reveals a bleeding fleshy mass. There is no lameness unless the lesions are thick and then break, splitting the skin as well, or if lesions occur in the interdigital space. All ages and breeds are susceptible but lambs, weaners and hoggets are most commonly affected.

Treat affected sheep with long-acting oxytetracycline (antibiotic) and ensure sheep are kept dry until lesion are healed and shear off the scabs.



**Strawberry footrot:** All classes of stock can be affected by strawberry footrot and infection is usually above the foot, up to the knee.



## Is it virulent footrot?

Different isolates (strains) of footrot bacteria can be classified according to their 'virulence'. Virulence is a measure of the bacteria's ability to digest the connective tissue below the horn of the hoof, which leads to under-running.

Highly-virulent strains of the bacteria can rapidly under-run the hoof horn, leading to hoof separation, severe lameness and associated production losses. Low-virulence bacteria (referred to as benign) are less able to do this and infection with these strains is usually confined to the skin between the toes, with occasional mild under-running of the soft horn only. Benign footrot does not usually cause severe disease and only leads to mild lameness, slight loss of condition and affected animals usually recover under dry conditions or with foot bathing. There are also intermediate strains that fit between benign and virulent.

It is often difficult to distinguish benign footrot from OID or the early stage of virulent footrot in the field as both conditions cause inflammation of the skin between the toes. The characteristic footrot odour can be present with benign footrot, but it is less obvious than in virulent cases.

Environmental conditions play a key role in expression of footrot. While the characteristic smell, discharge and under-running associated with later stages of virulent footrot make it relatively straight forward to diagnose in the field, benign footrot may reveal no outward clinical signs for much of the year if seasonal conditions are cold and/or dry. Laboratory tests can determine the virulence status of the footrot infection (see [Section 3. Laboratory diagnosis](#)).

## Guidelines for clinical diagnosis of virulence

If 1% of a mobs has score 4 or 5 lesions, virulent footrot is suspected. 🗨️

### Foot note



Take samples for laboratory diagnosis when any suspicious lesions (even score 1 and 2) are seen if sheep are to be exported to other states, or where there is a risk of introducing virulent footrot to a previously uninfected flock.

# Laboratory diagnosis

## Key messages

- Footrot is diagnosed in the laboratory using samples taken from lesions in the field.
- A range of tests can be used to determine whether footrot is present and the level of virulence of the given isolate (strain).
- An additional test can be used to identify the particular serogroups of bacteria present.

## Diagnosing footrot

Footrot is clinically diagnosed by evaluating characteristic foot lesions in the field and culturing the footrot bacteria (*Dichelobacter nodosus*) in a laboratory.

A prompt, accurate diagnosis helps to determine the best treatment program to reduce the impacts of the disease. The course of action needed will differ depending on whether benign, intermediate or virulent footrot is present.

Laboratory tests can determine both the presence and virulence of the footrot bacteria and the 'serogroup'.

There are 10 different 'serogroups' (groups of bacteria containing a common antigen) of footrot bacterium. Immunity to footrot is serogroup-specific, so if sheep are vaccinated with one serogroup-specific vaccine they can still be infected by other serogroups.

Knowing which serogroups exist within a flock is important when considering the use of serogroup-specific vaccines as a control treatment. See [Section 6. Specific vaccines](#) for more information.

## The testing process

### 1. Taking the sample

Collect material from the moist interdigital skin of the hoof, or from the advancing edge of an under-run lesion, by either scraping the affected area with a sterile scalpel blade or a cotton-tipped swab.

Place the collected scrapings or swabs in small sample jars containing a gel that helps to keep the footrot bacteria alive during transport to the laboratory.

If fast test results are required to simply determine whether footrot bacteria are present, smear a thin layer of the scraped material onto a glass slide, allow it to air dry and send to the laboratory. Keep in mind, this test will not determine the virulence or serogroup of the footrot strain.

More information about taking samples for laboratory testing is provided on [Section 4. Taking a sample.](#)

## 2. Determining presence or absence of the *D. nodosus* bacteria

### *Gram stain for microscopic detection of D. nodosus*

At the laboratory the smear prepared in the field is fixed and stained. A smear can also be made from the sample preserved in gel if a smear was not made in the field.

Under the microscope, using 100x magnification, *D. nodosus* bacteria appear as small reddish rods with rounded ends (see image right).

### *Culture*

To grow a bacterial culture, sample material is smeared onto agar plates containing ground up ovine hoof material and incubated in conditions that allow the bacteria to grow and multiply. The *D. nodosus* bacteria grow best at temperatures between 37–39°C, in conditions where no oxygen is present.

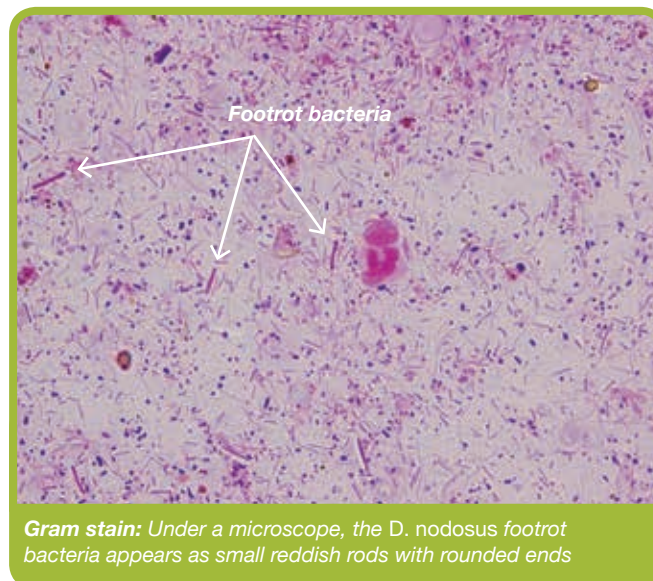

**Gram stain:** Under a microscope, the *D. nodosus* footrot bacteria appears as small reddish rods with rounded ends

The agar plates are examined after four days to see if bacterial colonies typical of *D. nodosus* have grown. If so, these colonies are transferred to another growth plate and incubated for a further four days. These colonies can then be tested (see Step 3) to determine the virulence and serogroup of the isolate (strain).

# Laboratory diagnosis

## 3. Determining virulence of the bacteria

### *Protease test (also known as the gelatin gel test)*

A protease test is used to differentiate virulent strains from benign strains of footrot.

Footrot bacteria digest the hoof by producing an enzyme called 'protease'. Virulent *D. nodosus* produces a more stable protease than benign isolates, and the laboratory test uses high temperatures to test the stability of the protease in the sample.

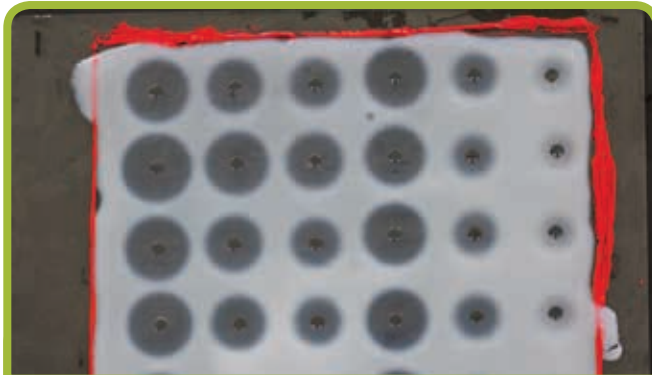

**Protease test plate:** *The protease test is commonly used but does not reflect the full range of virulence.*

The protease test is currently the most common test used to differentiate benign and virulent isolates, but it is a very 'black and white' test: it is either positive or negative, and does not reflect the full range of virulence, from benign to through to highly virulent. Some veterinarians feel the cut-off is too close to the benign end of the spectrum and some 'low intermediate' strains of footrot are currently classified as virulent by this test.

If the veterinarian feels the protease test has incorrectly classified the sample, an elastase or IntA PCR test (see below) can be used to clarify the virulence of the isolate under investigation.

### *Elastase test*

Elastase is another enzyme produced by some isolates of *D. nodosus*. It enables the bacteria to break down elastin, a component of the tissue connecting the hoof horn to the rest of the foot.

In this test the speed at which the bacterium breaks down elastin indicates its virulence. Test plates are checked every four days for up to 28 days to determine the results.

Virulent strains of *D. nodosus* bacteria take 4–12 days, intermediate strains take 16 days and benign isolates take 20–28 days to clear the plates. Some benign isolates do not produce enough elastase to clear the plates at all over 28 days.



**Elastase negative:** Bacteria is easily seen on the agar plate



**Elastase positive:** Hoof agar is clearing

### **IntA PCR**

An IntA PCR test is used to determine whether the 'IntA' gene is present in the strain of footrot bacteria being tested. Usually if this gene is found it indicates the strain is virulent. An IntA negative result is strongly associated with benign footrot, even in those cases where the isolate is positive on the protease test.

## **4. Determining which 'serogroups' of bacteria are present**

### **Polymerase chain reaction (PCR)**

Polymerase chain reaction is a technique used to copy a single piece of DNA from the footrot bacteria many times. This DNA material can then undergo a process known as 'electrophoresis' to produce a distinct pattern for each different serogroup of *D. nodosus* present. This enables each individual serogroup of footrot present in a particular sample to be identified by a letter of the alphabet (from A to I, plus M). The serogroup does not determine virulence of the *D. nodosus* strain present. For example, a virulent serogroup A and a benign serogroup A can be isolated from the same flock.

### **Slide agglutination test**

The slide agglutination test is a rapid screening test in which serogroup-specific anti-serum produced from a rabbit is mixed on a glass slide with some of the *D. nodosus* colony grown on the agar plate, and observed for a reaction (seen as flecks in the mixture if the colony is the same serogroup as the rabbit anti-serum).

The *D. nodosus* colony is tested against anti-serum to each of the different serogroups of footrot bacteria to determine the serogroup. 🐾

# Taking a sample

## Key messages

- Footrot can be clinically diagnosed by evaluating characteristic foot lesions in the field and culturing the footrot bacteria (*Dichelobacter nodosus*) in a laboratory.
- Provide the following guidelines to your veterinarian to ensure appropriate sampling procedures are carried out to determine the virulence and strains present.
- Sampling during periods that favour the expression of footrot ensures a more accurate assessment of the true nature and extent of the disease.
- Prioritise mobs, individual sheep and affected feet according to the aims of the footrot eradication program.
- Samples can be placed in transport media and on glass slides for transport to the laboratory; ideally within 24 hours of sampling.

Footrot can be clinically diagnosed by evaluating characteristic foot lesions in the field and culturing the footrot bacteria in a laboratory.

A prompt, accurate diagnosis helps to determine the best treatment program and reduces the impacts of the disease.

The course of action needed will differ depending on whether benign, intermediate or virulent footrot is present.



**Regular monitoring:** Signs of footrot are often more obvious during warm, wet weather (spread period). Lameness is usually the first indication of infection.

## When to sample

It is helpful to sample sheep for footrot when the disease is spreading (the 'spread period') and a full range of active lesions are present — usually when conditions are moist and warm. A flock infected with benign or intermediate strains of footrot may show few signs of footrot most of the year but the disease may reappear during a spell of warm, wet weather.

A flock infected with a virulent strain of footrot can also show few signs of infection until warm, moist conditions trigger the onset of sudden severe lameness in large numbers of sheep.



**Field sample:** Samples taken in the field can be sent for laboratory analysis to determine the strain and virulence of footrot.

It is difficult to sample sheep with deep-seated pockets of infection, and you are more likely to miss some less virulent, but still significant, strains by sampling during a 'non-spread period'.

Sampling during periods that favour the expression of the disease ensures a more accurate assessment of the true nature and extent of the disease.

Image courtesy: DAFWA

## Selecting suitable sheep

**Mob selection** – prioritise the mobs most likely to be affected by footrot. This could include:

- mobs with the greatest proportion of lame sheep and mobs with the greatest severity of lameness
- mobs of older ewes and rams
- mobs recently introduced to the property or those potentially exposed to strays or grazing adjacent to neighbouring flocks.

**Sheep selection** – sample sheep showing signs of lameness.



**Sheep selection:** When choosing sheep from which to take samples, select those with clear signs of lameness.

# Taking a sample

**Foot selection** – select a range of feet showing a variety of lesions, from score 2 to score 5 (if present) if the aim is to detect all serogroups/virulent strains present. If the aim is to determine the virulence of the most virulent strain present, select the feet with the highest score.

## Foot note



The more 'active' (plenty of moist, creamy exudate) and clean (free from mud or manure) the lesion is, the higher the chance of a successful culture. Dry lesions or heavily contaminated swabs reduce isolation rates in the laboratory.

If an individual sheep (for example a bought-in ram with a suspect foot) is presented for sampling, it may be worth wet bandaging for several days to encourage bacterial growth and increase the chances of culturing the footrot bacteria.

Do not take samples from fly-struck feet as the laboratory rarely isolates footrot bacteria from such samples.

## Sample number

Exercise judgment when determining the number of samples to take. If the laboratory has isolated *D. nodosus* from a high proportion of your swabs in the past, you can adjust sampling numbers accordingly.



**Foot selection:** The more 'active lesions', the higher the chance of a successful culture and meaningful test result.

If the aim is to detect all serogroups present, then sample at least 20 sheep from each mob. If there is a chance different mobs might be infected with different serogroups (for example bought-in sheep vs established mobs), then ideally sample 20 sheep from each different risk category. However, this is expensive in terms of laboratory costs, and it could be necessary to compromise. The greater the number of sheep sampled, the greater the chance of identifying all the different strains and serogroups of footrot present in the flock. Ten samples from the worst affected feet may be enough if the aim is just to decide whether virulent footrot is present.



## Lesion selection

Moist and active lesions are the most suitable for sampling. In early cases the moist exudate (discharge) from the inflamed interdigital skin or whitish–cream dead tissue from the skin–horn junction is ideal.

In more advanced cases, collect the moist, white or grey exudate taken from the advancing edge of the under-run lesion. Avoid faecal and mud contamination of the swab as much as possible.

## Preparation for sampling

When taking footrot samples, the aim is to keep the bacteria alive and remove competition from other contaminating bacteria. Footrot bacteria die in the presence of dry conditions, oxygen and sunlight so it is important to protect the swabs from air and light and to keep them moist.

Arrange a collection date with the laboratory to ensure staff are available to process the samples when they arrive. Allow sufficient time to collect samples and get them to the laboratory on the same day or collect later in the day and send overnight.

Have high-risk mobs (for example rams, older ewes, recent introductions, strays, mobs from the boundary paddocks) affected with footrot held in grassy paddocks close to the yards ready for sampling. Run sheep into the yards just before sampling to reduce mud and faecal contamination. Shedding sheep overnight before sampling can make sampling of score 2 lesions difficult.



**Sampling equipment:** Ensure sampling equipment is close to hand when taking samples. Transport media, cotton swabs and glass slides can be sourced from your laboratory.

## Foot-swabbing technique

Make sure all the necessary equipment and supplies are on hand — swabs, Stuart transport media and slides can all be sourced from your local animal health laboratory.

Select a lame sheep, preferably score 2 to 5. Remove mud and other material from the sole and interdigital cleft. Locate suitable lesions for sampling.

# Taking a sample



**Hoof preparation:** Carefully pare the hoof to remove overlying horn and any contamination to reveal a clean area of under-run infection.

Collect samples from interdigital skin (skin between the toes) rather than under-run areas if clean exudate is present.

Pare the hoof carefully using sharp footrot shears to remove overlying horn contaminated with faeces and soil, but avoid paring away all the under-run hoof – leave a clean area of under-run hoof over an area of active infection.

If the under-run area does not lend itself to uncontaminated swabbing, and there are plenty of sheep to choose from, record the footscores, raddle the sheep and let it go.

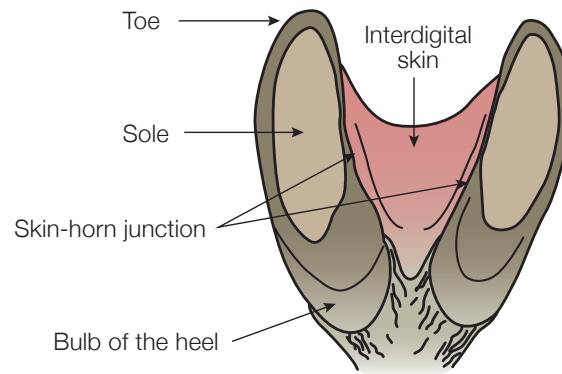

**Collection site:** Typical collection sites include the inflamed interdigital skin (if moist exudate is present) or whitish-cream dead tissue from the skin-horn junction.

## Foot note

When taking samples, clean the blades of footrot shears between each sheep with a clean section of paper towel – don't use disinfectant as it may kill the bacteria.

If the foot is suitable for sampling, proceed to take a swab. Use high-quality swabs packed individually. The cotton tip of cheap swabs will unravel and make it hard for the laboratory to get a useful culture.

Collect material by gently pushing the cotton tip of the swab into a clean, actively-infected area. Roll the cotton tip and rub it over the affected area for about 30 seconds to ensure plenty of exudate soaks into the cotton tip.

When obtaining a sample from an under-run lesion, pare the foot to remove most of the overlying horn, then cut a flap of horn over the most advanced edge of the lesion, lift the flap to allow access to the deepest, most active, least contaminated exudate and pass the swab under the flap to soak up as much of the least contaminated creamy footrot exudate as possible.

Only swab one foot on each sheep if possible to maximise the chances of finding all strains present in the mob. If few infected animals are present, sample more than one infected foot from a single sheep.



**Sampling technique:** Rub the swab in clean exudate in an active lesion, under a flap of sole, in a well-prepared hoof.

# Taking a sample

A smear can be prepared on a glass slide before placing the cotton swab in the transport media, by rolling the swab on a clean glass slide after rubbing it in the exudate. Label the slide with sheep tag number, mob and property, allow it to dry and place in a slide transporter for delivery to the laboratory.

After preparing a slide, push the cotton tip deep into the transport media and break off the stick, screw on the lid, label, and store out of sunlight in an esky or similar container. Use one media bottle for each swab.

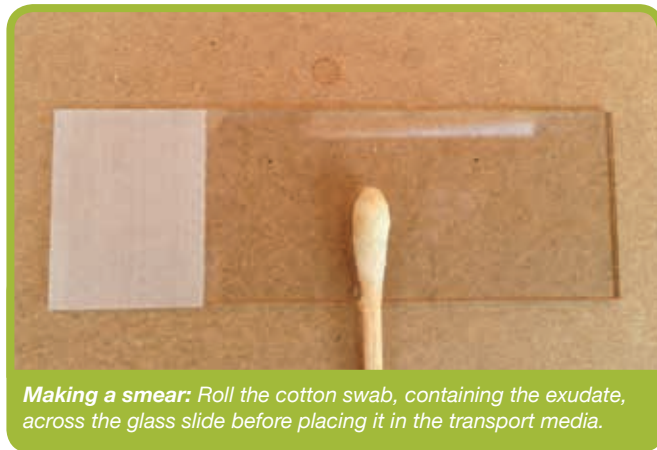

Stuart transport medium used for swabs is generally more liquid than that used for scrapings. Different laboratories vary slightly in their formulations of transport media, so contact your laboratory to determine the preferred specifications for sample transport.

The amount of material collected from a lesion is often small so transport media may be modified to contain a higher concentration of agar in order to prevent dilution of the sample and to help maintain anaerobic (oxygen-free) conditions.

The colour of the transport medium should be cloudy grey. A strong blue colour indicates the medium has oxidised and is unsuitable for use.



**Suitable medium (left):** Transport medium should be cloudy grey in colour.

**Unsuitable medium (right):** A strong blue colour indicates the medium has oxidised — do not use.



**Storing the sample:** Push the swab into the cloudy grey transport media and break off the stick.

## Transporting samples

Unused transport media needs to be kept cool with ice bricks in an esky. After samples have been taken, some laboratories prefer the samples to be kept at room temperature stored in an esky with no ice bricks. Contact your laboratory to determine their temperature requirements for samples during transport.

Ideally samples should be submitted to the laboratory and plated out within 24 hours of collection. Prompt processing of the samples at the laboratory after collection improves the chances of successful culture and isolation of the footrot bacteria. Contact the laboratory if delays of more than 48 hours between collection and plating out are likely.

If serotyping is to be carried out, regional laboratories will send pure *D. nodosus* colonies to the University of Sydney for serogroup PCR testing. Stuart transport media is not suitable for transport of isolated colonies, these should be sent on hoof agar plates. 📧

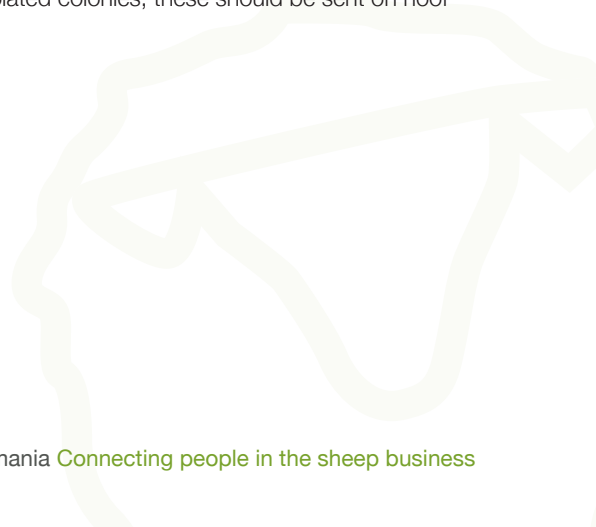

# Eradication

## Key messages

- The aim of any footrot eradication program is to reduce the prevalence of the disease to a level where all remaining infected sheep can be culled.
- Successful footrot eradication requires: planning, control, eradication and surveillance.
- Eradication involves controlling footrot during the spread period and immediately afterwards, by combinations of regular footbathing, foot paring, antibiotics, and possibly vaccination, followed by culling inspections during the dry, non-spread period.
- Careful consideration needs to be given before embarking on an eradication program — it is a costly process, which requires sound on-farm biosecurity measures, skilled and thorough operators and vigilant monitoring and management.
- Footrot eradication can only be considered successful when all sheep have been through a spread period without any evidence of footrot.

## Eradication program aims

In order to eradicate footrot from any given property, all *Dichelobacter nodosus* bacteria must be killed or the infected sheep culled.

The aim of an eradication program is to get the prevalence of footrot low enough to be able to remove all remaining infected sheep from the property.

Curative treatments should be applied during and immediately after the spread period to reduce the number of sheep needing to be culled.

Most eradication programs involve controlling footrot through the spread period and immediately afterwards, by combinations of regular footbathing, foot paring, antibiotics, and possibly vaccination, followed by culling inspections during the dry, non-spread period.

It is difficult to undertake an effective culling program during spring as the disease is still spreading from sheep to sheep and ewes are usually lambing — it is better to wait until the end of the spread period to start culling inspections.

An eradication program planned in conjunction with, and closely supervised by, an experienced veterinarian has the best chance of success.

While eradication programs can vary from farm to farm, depending on farm management practices, bacterial strains and virulence, they all have four basic stages: planning, control, eradication and surveillance.



**Risk assessment:** *It is critical to evaluate the risk of reinfection from stock movements before embarking on a footrot eradication program.*

**NOTE:** *The presence of deer and cattle on the property should not deter an eradication attempt.*

## Planning

A practical and detailed eradication program needs to be developed, preferably in consultation with a veterinarian or farm adviser. This program needs to consider:

- a. Whether the strain of footrot is virulent enough to warrant eradication: It is not possible to eradicate benign footrot, especially if cattle are present, and some strains of intermediate footrot in low-rainfall areas may not be worth eradicating.
- b. The risk of re-infection: It is pointless to undertake an eradication program if there is a high risk of reinfection. Answer the following questions about property biosecurity to determine whether measures can be applied to eliminate any source of re-infection before considering an eradication program:
  1. Can all boundaries be secured so infected stray sheep or goats are unable to access the property?
  2. Can all sheep and goats on the property be mustered (or otherwise eliminated)?
  3. Can any introduced sheep and goats be kept isolated from the flock until they are confirmed to be free of footrot?
  4. Can sheep and goats be transported and returned to the property without reasonable risk of contracting footrot during their absence?
  5. Do sheep have to walk between separate properties, across other sheep properties or on public stock routes or roads, etc.?
  6. Are store lambs brought in from other properties each year?
  7. Are sheep or goats agisted on or off the property frequently?

# Eradication

## c. Property management practices, flock structure and facilities.

1. **Fences:** Internal fences need to be secure enough to guarantee all sheep are mustered for inspections.

Not every fence on the property has to be sheep-proof, but enough secure paddocks with adequate feed must be available.



**Handling equipment:** Effective sheep handling equipment will relieve the physical burden of inspections and increase the efficiency of the process.

2. **One-year plan:** Eradication must be planned to be completed in one year across the whole property — unless it is possible to keep mobs completely separate.

If the property is divided by a road or the different mobs of sheep are kept on separate properties it may be possible to concentrate on eradicating footrot from a portion of the flock in the first year. However, for this to be feasible, absolute separation of the mobs needs to be possible, including separate yards, shearing and dipping facilities for each mob.

If (and only if) the mobs can be kept separate, ewes and younger sheep could be prioritised for eradication in the first year. Sell cast-for-age sheep for slaughter and undertake eradication for the wether portion of the flock the following year.

3. **Handling facilities:** Fatigue is an important factor when inspecting and culling sheep as operators aim to detect every small pocket of infection.

Effective sheep handling equipment is a worthwhile investment. It is worth ensuring the lead-up race is well designed and positioned so sheep flow well into the handling equipment. If significant numbers of sheep are involved, handling them over the shearing board is impractical.



Lighting is critical. Working outside will provide sufficient light, but a roof or shelter may be required to prevent sunburn and for wet weather. If working inside the shearing shed invest in plenty of high-quality fluorescent lighting, which minimises shadows.

Laneway systems that prevent infected and clean sheep crossing paths can be important during the spread period, if it rains during an eradication inspection period, and after eradication when handling introduced sheep. If it is a dry, non-spread period during an eradication inspection period it does not matter if mobs cross paths.

4. **Skilled personnel:** Eradication can only be achieved by repeated inspections of all feet on all sheep. Farm staff or contractors can undertake these inspections, but there must be a genuine commitment to finding every infected sheep — this includes clean mustering as well as rigorous foot inspecting.

### Foot note



Any person undertaking an inspection needs to be well trained, methodical and have the time and patience to do the job properly so ALL infected sheep are identified. An effective principle is to have the person with the most to lose carrying out the final inspection on each sheep.

If using farm staff for culling inspections, consider working for the morning on footrot and then carry out other work in the afternoon if possible.



**Skilled operators:** *It is essential all staff or contractors are well trained, methodical and committed to finding every infected sheep during the inspection process.*

At least three inspections are required before the autumn break. As the non-spread (dry) period can be relatively short (2–4 months), inspections need to start soon after the end of the spread period and be scheduled to continue through the non-spread period.

Carry out inspections every 4–6 weeks. On some large properties it is simply not possible to inspect all sheep three times during an average summer with existing staff and/or facilities, however these inspections need to be considered a priority. Other farm work needs to revolve around the footrot program. If labour resources are limited, consider employing skilled and reliable contractors. Without a commitment to inspections, an eradication program is unlikely to succeed.

# Eradication

5. **Financial considerations:** An eradication program can be expensive and time consuming and may not be successful in the first year. Half measures are unlikely to result in success. Fences and other facilities may need to be upgraded, sheep handling equipment purchased, additional labour or contractors employed, and culled sheep will probably be sold at a discount.

Young sheep may need to be retained to replace culls and store sales may be reduced. Time and financial costs need to be fully assessed before committing to an eradication program.

Have a contingency plan in place in case the disease reappears in one or two mobs following the eradication phase — separate areas (with separate handling facilities if possible) need to be available so clean and infected mobs can be kept separate if this situation arises. This can incur more expense.

**d.** To proceed or not?

If any of the major factors listed appear impossible to achieve then eradication may not be possible and it may be better to revert to a control program.

## Control

Effective control measures employed during the spring spread period aim to reduce the number of chronically-infected sheep to a level that allows them all to be culled during the eradication phase. This can be difficult in spring-lambing systems, where ewes and lambs cannot be disturbed during lambing and after marking.



**Effective control:** Control during the spread phase can be achieved by footbathing, foot paring followed by footbathing or vaccination, or a combination.

If too many sheep are still infected as the non-spread period starts, it may be possible to use antibiotics or a vaccine with a high cure rate at this time. Sometimes it is necessary to wait a few years for a dry spring with little spread and then take advantage of the low infection rates going into summer.

If effective control is achieved during the spread period there will be far fewer sheep with severe lesions during summer inspections, so the decision to cull is straight forward. Without effective control the number of sheep with severe lesions during summer may be too great to cull them all.

Control during the spread phase can be achieved by foot paring/footbathing or vaccination, or a combination of both (see [Section 6. Specific vaccines](#), and [Section 8. Treatments](#)).

### Footbathing and vaccination

Footbathing can reduce the severity of infection and the number of sheep infected during the spread period and helps heal affected feet, but when used in isolation it won't eradicate footrot.

#### Foot note

Footbathing and vaccination used in combination are effective in controlling the spread of footrot during the spread period; often reducing the incidence of infection within the flock to less than 5–10%.



### Antibiotics

Sometimes, control strategies may not have reduced the incidence of disease after the spread period to a level (usually below 5–10%) where culling all remaining infected sheep is practical. Antibiotics can be used to try to reduce the numbers needing to be culled or to try to salvage particularly valuable sheep.

There are risks associated with adopting this option as antibiotics will not cure all sheep affected with footrot. The longer these non-responders remain on the property during the eradication program, the greater the risk of them infecting clean sheep. Consult a veterinarian before deciding to use antibiotics during an eradication program.

Cull any sheep that do not respond to antibiotic treatment after the first inspection as soon as the withholding period has expired —DO NOT treat any sheep for salvage at subsequent inspections. Antibiotics are only available through a veterinarian and correct dosing is important. Sheep need to be kept on grating for 24–36 hours after treatment to ensure feet remain dry immediately after treatment. After this period run treated stock in dry paddocks for a month until the first culling inspection.

Long-acting oxytetracycline antibiotics are considered the most effective for treating footrot. Always observe withholding periods before sending non-responder sheep to slaughter.

Footrot is eradicated by culling, rather than treating infected sheep. Programs are likely to fail if too much time is spent trying to cure infected sheep rather than focusing on detecting and culling any carriers.

# Eradication

Control treatments, such as footbathing and antibiotics, applied during the eradication phase of the program increase the difficulty of detecting sheep still not completely free of infection and hence increase the risk of eradication program break down. More importantly these procedures take time and distract from the most important task – culling infected sheep.

## Inspect and cull

When effective control of footrot is achieved, thoroughly inspect all the feet of all the sheep in the flock after the spread period has finished (usually during the dry conditions of summer). Don't run sheep on irrigated paddocks during this period.

A decision needs to be made whether to:

- a. de-stock mobs with too many infected sheep,
- b. cull individual infected sheep, or
- c. treat infected sheep (only consider this option when too many sheep are still infected at first inspection and culling them all is not an option. Give them one go early in summer, consider antibiotics).

The aim of the eradication phase is to identify and remove all the remaining infected sheep from the flock when footrot is not spreading, so they cannot re-infect clean sheep during the next spread period. If it is truly a non-spread period (dry underfoot, short grass, no dewy nights), there is no need to have sheep enter and leave the facilities by different routes.



**Thorough inspection:** Following effective control it is important to inspect again every foot on every sheep in the flock after the spread period has finished.

## Foot note

DO NOT have a 'hospital' or 'suspect' mob. Infected and suspect sheep must be identified, placed in a secure paddock and sent for slaughter as soon as practical. Time spent on these sheep is time not spent making sure there are no carriers in the clean mobs, and infected sheep remain a risk to eradication every minute they remain on the property.

Turn over and individually examine every sheep at each inspection, paring sufficiently to make an accurate diagnosis. The first inspection will be slow as feet will often be long and deformed. Subsequent inspections will be faster as minimal footparing should be required. When foot paring, take care to avoid causing any bleeding, be methodical, don't try to break any time records.

All feet of all sheep need to be re-inspected 4–6 weeks later and all infected sheep culled. There should be no further treatment for sheep treated at the first inspection.

Generally less than 1% of sheep will be detected with footrot at subsequent inspections. Identify infected sheep with a distinctive colour mark or branding fluid on their head. Use a different colour on clean sheep – this helps assess how effective mustering and fences are.

### Foot note



When inspecting feet, the golden rule is “IF IN DOUBT THROW IT OUT”. Don't look at the wool, the mouth or the pedigree, if it has a suspicious foot, cull it. Get all infected sheep off the property as soon as possible to reduce the risk of accidental mixing.

After all infected and suspect sheep have been culled, carry out a further two clean inspections — where no footrot is found — before spread conditions return (see *Section 7. Eradication inspections*).

## Surveillance and prevention

Footrot eradication can only be considered successful when all sheep have been through a spread period without any evidence of footrot. Ongoing monitoring is essential after a mob has gone through the intensive control and eradication program to ensure footrot has been eradicated and to prevent reinfection.

Keep all mobs as separate as possible through the next spread period so if a breakdown occurs it is limited to a single mob. Don't mix sheep unnecessarily, don't cross paths without a seven-day spell between mobs if possible, keep footbathing mobs as they leave the yards.

Regularly observe all sheep and examine any lame sheep throughout the following spread period. Mark the sheep after examination. If footrot is found, take measures to ensure infection does not spread to other mobs. Run an eradication program on the infected mob next summer or cull the whole mob.

After the spread period inspect all mobs again to ensure the eradication program has been successful. If the spring period has been dry, or the strain eradicated was of intermediate virulence, take particular care when undertaking this final inspection (see *Section 10. Prevention and surveillance*).

Surveillance needs to be ongoing — especially in boundary paddocks, and for introduced mobs.

Prevention involves employing a program for introduced sheep to ensure they don't bring footrot back onto the property, and maintaining secure boundaries. Have an agreement with neighbours that they don't just drop your sheep back over the fence. 🐾

# Specific vaccines

## Key messages

- Specific vaccines can be used to treat known virulent footrot serogroups and reduce disease prevalence.
- Producers using specific vaccines need to know which serogroups are present in their flock and be vigilant in their approach to disease eradication and ongoing management.
- Ongoing flock monitoring and on-farm biosecurity are critical to keeping footrot out after eradication.

Specific serogroup footrot vaccines (SFV) can be used as part of a footrot eradication program to reduce disease prevalence and increase the effective non-spread period, by providing six months, of immunity in vaccinated sheep.

### What are specific serogroup footrot vaccines?

A specific vaccine is a custom-made vaccine that targets the serogroups of footrot present on any given property. There are 10 main serogroups — A to I and also M.

While vaccines can be produced that target multiple serogroups, the efficacy of the vaccine is reduced if more than two serogroups are incorporated into a single vaccine.

A vaccine containing only one or two serogroups causes sheep to produce much more immunity to each serogroup than a 10-serogroup vaccine, delivers much higher cure rates and a longer (six-month) protection period.

## Specific vaccine research

A University of Sydney research project started in Tasmania during 2007, using specific vaccines in four medium-sized flocks. One flock with only two virulent serogroups eradicated the disease promptly. The other three flocks had multiple serogroups and have now eradicated most of the virulent serogroups.

DPIPWE has completed on-farm trials to see whether large properties can eradicate footrot with veterinary practitioner support. There were 21 properties in the trial, 14 were control properties and seven were treatment properties.

Five of the seven property managers that vaccinated were satisfied with the results, one was burnt out and it is too soon to report results on the other. Only one control property eradicated footrot, but at a high cost.

## Procedures for successful footrot eradication using SFV

1. The property manager must be confident that once eradicated, footrot can be kept out through rigorous biosecurity measures.
2. The veterinary practitioner collects swabs from 20 sheep, representing different age groups and mobs.
3. The regional animal health laboratory grows the footrot bacteria from the swabs (this takes about two weeks and costs about \$1000), and sends up to 20 isolates (samples) to the University of Sydney to determine the virulence and serogroup.
4. The University of Sydney grows the isolates and tests for virulence and serogroup (this can take up to four weeks and can cost about \$3000 for 10 isolates).
5. A pilot group of 100 infected sheep can be vaccinated to provide confidence all serogroups have been detected. If too many sheep don't respond to a full course of vaccination, some non-responders can be swabbed and serogrouped.
6. If the property manager decides to proceed with vaccination, an order for the number of doses required is sent to the vaccine manufacturer.
7. The manufacturer will probably supply the vaccine as single serogroups in plastic collapsible vaccine packs. This will allow immediate supply and top-up orders, and make vaccination more economical than previously for properties with one or three serogroups. If more than one serogroup is present, it is advisable to administer each vaccine via a separate syringe on opposite sides of the body, for example, one behind the left ear, one behind the right ear. Vaccination will cost about \$1 per dose. This means vaccine costs will be about \$2 for a full course of two shots of monovalent (active against a single serogroup), about \$4 for a full course if there are two serogroups and so on.

# Specific vaccines

8. The property manager must vaccinate all sheep on the property — apart from prime lambs and culls that can be identified and kept separate. This vaccination course may be completed before lambing and the spring disease spread (transmission) period, or given later, but the last booster must be given no later than four weeks before the eradication inspections are planned to start (e.g. December in Tasmania), so they can be carried out and completed during dry summer weather (the non-spread period).



**No second chances:** Following the vaccination program clearly identify and cull any sheep showing signs of infection.

9. Four to six weeks after the initial vaccination, a booster shot is required. The time between vaccinations must not exceed six weeks (the first vaccination must be timed so the booster can be given within the six-week time frame).
10. Vaccinated ewes will give some 'passive' immunity to their lambs, but this will only last eight weeks. Lambs can be vaccinated at marking, or footbathed to keep the prevalence low until weaning/eradication inspections.
11. If there are more than two serogroups present in the flock, the process must be repeated, starting 12 weeks after the start of the first course of vaccinations.
12. Four weeks after the last vaccination, foot inspections must start and from here on the process is identical to conventional eradication. These inspections involve careful paring and investigation of each foot of all 'keeper' sheep to determine whether the sheep are still infected with footrot or not.
13. If more than 5% of sheep are still infected at first inspection, more swabs may need to be taken to see whether another serogroup of footrot is present.
14. Infected sheep must be identified (for example, with red branding fluid on the head) and isolated until they can be removed from the property. Don't waste time treating these sheep.



15. Inspections must be repeated every four weeks until all infected sheep have been culled and removed (at least one 'clean' inspection must be achieved). The specific footrot vaccine gives 6–9 months protection and creates a non-transmission period. This means eradication inspections may continue even if there is an early autumn break, but benign strains may cloud the picture by causing confusion about what to do with sheep showing score 1 and 2 lesions.

### Monitoring

When footrot appears to have been eradicated, monitor for a breakdown. Check any lame sheep as soon as they are detected. If footrot is found, isolate the affected mob and decide whether to inspect and cull again, or whether to take another set of swabs.

Continue to monitor for as long as footrot is assumed to have been eradicated.

### Introducing new sheep

Ask the vendor to provide a Sheep Health Statement with the footrot section completed.

Inspect all introduced sheep, including rams, on arrival, footbath and isolate for as long as possible (a minimum of 6–8 weeks), even sheep that have been bought in from properties with a 'footrot-free' reputation. Ideally, isolate these new sheep in a wet paddock where footrot is likely to show up before being mixed with other sheep.

### Ongoing biosecurity

Maintain sheep-proof boundary fences as much as possible.

Ask neighbours to keep any of your strays and ensure you pick them up, rather than having a neighbour drop them back over the fence. Treat these as new introductions (see left).

If a neighbour's sheep stray onto the property, immediately isolate the mob, remove the strays, inspect their feet and take appropriate action based on the status of their feet and current conditions underfoot.

### Vaccine progress

The use of SFV is still in its early stages, but the technique shows promise. 🗨️

#### Foot note



There are some expenses producers must be prepared for, and results are not guaranteed. Post-vaccination inspections and culling of all infected sheep are critical and must be carried out thoroughly if the eradication attempt is to be successful.

# Eradication inspections

## Key messages

- Eradication inspections are absolutely critical to the success of any footrot eradication program.
- Sheep handling equipment will reduce operator fatigue and increase handling efficiencies.
- Developing a well-thought-out program will ensure the inspection operation is carried out in a timely manner, reducing the conflict with other farm jobs.
- A thorough inspection technique is critical to ensure every last foot is inspected, all sheep infected with virulent footrot are identified and appropriate measures are taken in a timely manner.

Eradication inspections are absolutely critical to the success of any footrot eradication program. Every last infected foot needs to be found and the affected sheep culled to achieve a footrot-free flock.

Weight the dice in your favour. Get well set up, establish some clear rules-of-thumb and proceed with confidence.

### Efficient handling facilities

Unless sheep numbers are low, use effective and efficient sheep handling equipment or employ contractors.

Sheep handling equipment will reduce operator fatigue, footparing will be more accurate, there will be less blood, and any footrot lesions will be more visible. Sheep throughput will be increased with the right equipment, leaving time for other jobs.

While it is critical to have good lighting, and working outside in the yards provides plenty of light, operators also need to be protected from sun, rain, dust and wind. If working inside a shed, have plenty of cool fluorescent lights set up so shadows don't fall over the sheep's feet.



**Ease of handling:** Well-designed sheep handling equipment can ease the load of eradication inspections, reducing operator fatigue and increasing handling efficiencies.

A constant flow of sheep is important, as is a set-up where sheep move into the handler without too much coercion. Well designed, sound fences and yards will support efficient sheep flow. Skilled dogs and sufficient labour to keep sheep up to the person doing the foot inspections also is important.

## Be prepared

The key to avoiding operator fatigue and ensuring a thorough inspection is to develop a well-oiled routine — don't try to break any world foot inspection records.

The first inspection usually takes longer than subsequent inspections as more paring tends to be carried out first time around. While the subsequent inspections often are faster, don't get carried away — still inspect every foot thoroughly.

Inspecting a mob in the morning followed by less demanding tasks in the afternoon, can prevent fatigue from affecting results late in the day. Take breaks as required, keep up fluids and eat enough food to stay bright and alert.

Some experts claim the person with most to lose if eradication fails should make the final decision on each sheep. In any case, the people carrying out these inspections, and making the decisions, must be motivated and genuinely keen to see the disease eradicated.

### Foot note

DO NOT have a hospital mob!!! Concentrate all your efforts on clean sheep. Treatment may be an option early in the non-spread period if the prevalence is too high to cull all infected sheep, but any infected/suspect sheep from then on must be culled. Mark culls, keep them in a secure paddock and send them to the abattoir (as long as they are fit to load and all withholding periods have expired) as soon as possible.

# Eradication inspections

Infected/suspect sheep must be well-marked in case they escape from their paddock or get mixed up with another mob for some other reason. Identifying clean sheep helps identify clean musters. Poll dotting with branding fluid for both clean and infected/suspect sheep ensures sheep can be clearly identified. Use branding fluid rather than spray marker, as branding fluid lasts longer and doesn't fade as easily. Keep in mind some wool may be classed into 'brands' at shearing. Be aware of blue/green colour-blindness when selecting colours.

Spelling paddocks, laneways and yards between inspection mobs is not usually necessary if inspections are carried out during a true non-spread (dry) period and sheep have been footbathed as they leave the yards.

Repeat inspections at 4–6 week intervals. Carry out at a minimum of three inspections, aiming for at least two 'clean' inspections, before the non-spread period finishes.

## Inspection technique

For second and subsequent inspections, it is not necessary to pare at all if the foot is clean and healthy and the wall and toe are not overgrown. Always twist the heels as some score 3 lesions can be present in a foot that looks fine on visual inspection alone and even after paring of the toe and wall.



**Thorough inspection:** Always twist the heel when inspecting for footrot to reveal any hidden lesions.

It is difficult not to have some bleeding at the first paring/inspection when re-shaping deformed feet, but try not to draw blood at the subsequent inspections, as it will cover up lesions and make diagnosis more difficult as it will be challenging to assess whether the lesion surface was originally moist.

Use consistent culling criteria and apply the precautionary principal – “if in doubt, throw it out”. Don’t look at the wool, the teeth, the pedigree or anything else!

Old toe abscesses can be hard to differentiate from footrot — cull anything suspicious. Do not confuse shelly toe with chronic footrot lesions.

One vexing problem can appear if there is a little rain and some score 1 feet appear — some reddening is visible and maybe a small amount of exudate (fluid) and moisture on the inter-digital skin.

If there are too many sheep to cull, just mark them, footbath the mob for at least 10 minutes and re-inspect in 7–10 days. If the lesions are all healed when next inspected, it was only bacterial dermatitis or benign footrot, but if still present, with some maybe progressing, it is best to get some laboratory work done to determine virulence.

### Foot note



Always examine the feet in the same order and minimise distractions, if you stop to talk to someone, or do something else, start from the first foot again. Likewise, always pare the foot the same way, ensuring any defects are detected. Use the sole as a guide, if you keep parallel to — and level with — the sole bleeding will be avoided. Some elongated toes have to be cut off to get started, but don’t cut too close to the sensitive tissue.



**Consistent approach:** Pare each foot in the same way and ensure any defects or infection sites are detected.

Chronic ‘carrier’ lesions can be found under the heels, under the wall, in the toe area and under the flap of hard horn inside the front of the toe. Sometimes the lesion heals from the toe back down the foot and the lesion is in the heel area and even the back part of the wall. Use well-sharpened hand-held footrot shears and pneumatic shears — hand-held shears for paring away suspect lesions at tricky angles and pneumatic shears for the really hard horn. Some people use a sharp horse hoof knife as well.

Large distorted ‘club’ toes can be hard to investigate properly and sometimes these sheep are best culled.

See [Section 2. Identifying footrot in the field](#) for some descriptions and photos of a range of footrot lesions and other foot conditions, which can be mistaken for footrot. 🗨️

# Treatment

## Key messages

- A number of treatment options are available to control and eradicate footrot — options vary in their efficacy, expense and time taken to employ.
- Culling is a critical part of any control and eradication program — cull all non-responders.
- Foot paring is an important part of both the diagnostic process and control program. Always take care to avoid excessive paring and unnecessary blood loss.
- Footbathing, in combination with paring, is a commonly-used and potentially successful treatment option.
- A range of footbathing chemicals are available.
- Antibiotics are most effective when sheep are pared, footbathed, injected and kept on slatted floors for 24–36 hours after treatment.
- Footrot vaccines can be used to treat footrot – for more information read *Section 6. Specific vaccines*.

Curing and preventing footrot is an important part of both ongoing control and eradication programs.

Treatment options include: selective culling, paring, footbathing and antibiotics, plus various combinations of these treatments.

Treatments vary in effectiveness, cost, and how long it takes to treat the sheep. Different treatments are suitable for different situations and managers need to know what treatments are the most appropriate at different stages in the management cycle.

### Selective culling

In eradication programs all infected sheep must be culled over a non-transmission (non-spread) period. For ongoing control programs, culling of the worst-affected sheep is a good policy both for animal welfare and productivity reasons.

Many producers pare and inspect sheep during early summer, immediately after the major spring spread period, and cull any sheep with score 5 feet.

Susceptibility to footrot is hereditary and consistent culling is likely to reduce the prevalence over a period of years in closed flocks.

## Paring

Full paring involves using either hand-held or pneumatic footrot shears to cut away the under-run sections of the hoof. Footrot bacteria do not survive long when exposed to oxygen, and thorough paring alone can cure up to 50% of sheep with score 3 and 4 footrot.

Full paring is time-consuming, often bloody, painful for the sheep, and is best followed by footbathing. Many producers only fully pare score 3 and 4 sheep and cull the score 5 sheep as soon as paring reveals score 5 footrot.

Diagnostic paring is a limited cutting away of the hoof to show how far the under-running has progressed, and avoids bleeding.

Use sharp hand-held and pneumatic shears for paring: pneumatic shears for the really hard horn and hand-held shears for paring at tricky angles and for diagnostic work.

Some people use a sharp horse hoof knife as well.

Pneumatic shears make paring feet quicker and easier and are particularly useful during summer when the hoof horn is very hard and excess hoof material needs to be removed.

Hand-held shears are useful for re-inspections during eradication programs.



**Diagnostic foot paring:** 1. Cutting off the long toe safely. 2. Taking off the overgrown lateral wall. 3. Sufficiently shaped, but under-run footrot apparent in bottom-most toe needs attention. 4. Paring back under-run toe, avoiding blood loss.

# Treatment

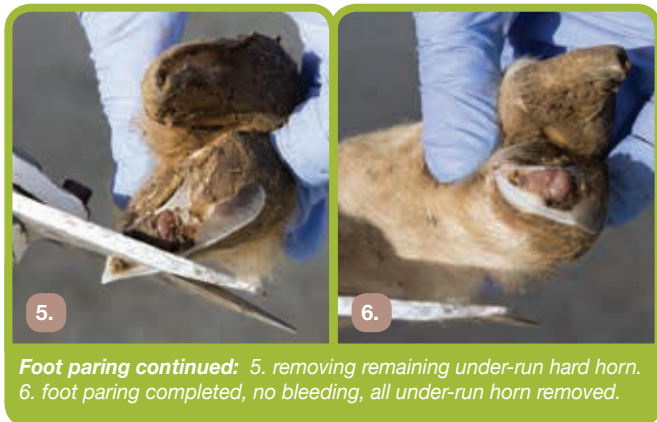

A common mistake is to pare too heavily, causing bleeding and lameness. Paring that leads to profuse bleeding impacts negatively on sheep welfare and will not improve cure rates.

Avoid bleeding when conducting diagnostic paring during eradication inspections, as blood obscures footrot lesions, making diagnosis difficult.

When reshaping deformed feet, use the sole as a guide — keep parallel to, and level with, the sole to avoid excessive bleeding. Some elongated toes have to be cut off to get started, but don't cut too close to the sensitive tissue.

## Footbathing

Footbathing is the most commonly-used option to control footrot. It is a cost-effective method of applying chemicals to the feet of a large number of sheep in a short time. Used properly, footbathing assists healing of score 1 and 2, some score 3 un-pared feet, and pared score 3, 4 and 5 feet. It prevents new cases for a period and, if used regularly before infection can proceed to under-running, can effectively control virulent footrot.

Footbath chemicals only kill on contact, and while most footbath solutions are effective at curing and preventing score 1 and 2 (benign) footrot, they will not cure many sheep with extensive under-running (score 4 and 5).

Footbathing is more effective if preceded by foot paring of score 3, 4 and 5 feet. Cure rates for chronic score 5 feet that are pared and footbathed rarely approach 70%.

The response to footbathing depends on when and how it is used. If employed early in a spread period, and used regularly, footbathing usually results in a positive response.

Footbathing will help to reduce the number of sheep picking up new infections during the spread period by curing score 1 and 2 lesions before under-running develops, also reducing disease transmission and risk of spread to other sheep in the mob. Keeping the number of infected sheep to a minimum will improve the chances of successful summer eradication.



## Foot note



Footbathing alone will not eradicate virulent footrot from a mob or flock.

A well-designed footbathing program can help minimise the number of sheep needing to be culled at subsequent eradication inspections, but managers must be aware that lameness can be masked by footbathing and that repeated foot inspections are the only way to determine whether all infected sheep have been removed from a mob.

For properties with large numbers of sheep, footbathing is time-consuming unless a large footbath is built. Footbathing is not practical for ewes with lambs during the spring spread period, as it can increase the risk of mismothering. This limits the effectiveness of footbathing on most sheep breeding enterprises.

## Footbathing chemicals

### Zinc sulphate

Zinc sulphate is a popular footbath chemical. Zinc can be reused since it remains effective even in the presence of organic matter, such as plant debris, faeces and soil. Zinc sulphate is not a strong irritant, is safer and gentler on sheep, and does not cause hoof hardening.

It is important to note that zinc is a heavy metal, can be toxic if ingested, and does kill vegetation. Thirsty sheep that drink from the footbath may die of acute zinc poisoning.



**Footbathing:** Footbathing chemicals only kill on contact and will be most effective when preceded by foot-paring.

Zinc sulphate does not give off fumes and can be used inside or under a shed.

# Treatment

## Zinc formulations

Some zinc sulfate products are registered for treating footrot. If using a registered product always follow the label directions.

Zinc sulphate heptahydrate may be used as a 10% or 20% solution. Leave sheep standing in a 10% solution for about 10 minutes. Alternatively a long, slow walk through a 10% solution followed by half an hour standing on a dry surface is also reasonably effective.

Zinc sulphate mixed at 10–20% with 2% lauryl sulphate added is more effective if the sheep stand in the solution for about an hour. Zinc will penetrate about 1mm into the soft horn of the sheep's feet under these circumstances, and this can cure some score 1, 2 and early score 3 feet without any paring. This treatment method usually gives about three weeks protection during the spread period.

Zinc will 'strip' from such footbaths used in this manner, and a hydrometer can be used to maintain the zinc concentration above 10%.

Formalin causes chemical changes in the feet which interfere with the absorption of zinc. Previous footbathing with formalin will interfere with the penetration of zinc into the foot for about eight weeks. During this period zinc will act only as a surface disinfectant and will not penetrate into the foot.

## Zinc concentration

Zinc does not evaporate, but the water in the mixture does. This means over time, an unused footbath not diluted by rainwater will become stronger. If the footbath dries right out, the zinc will crystallize in the bottom. In all cases, simply re-fill the footbath with water to the level it was at when the last footbathing session finished and check the concentration with a hydrometer.

To maintain adequate working strength the use of a hydrometer or concentration tester is recommended. The hydrometer measures the chemicals dissolved in the solution and will give a guide to strength. Fine solids in suspension may artificially raise the specific gravity but only by a small percentage. When taking a sample for testing, scoop it off the surface before the footbath is stirred up, or filter the sample before measuring the specific gravity.

It is best practice to measure the strength of the footbath solution with a hydrometer at least twice daily during long footbathing sessions. At a 10% solution the hydrometer should read 1050–1060 units.

If the concentration is too low add 2.5kg zinc sulphate per 100 litres of water to increase strength by 10 units.

If the concentration is too high add 25L water per 100L to decrease by 10 units.

Beer and wine testing hydrometers are suitable for use and are available from home brewing outlets. On many properties the use of a tester reduces the amount of zinc sulphate used by 50%.



**Hydrometer:** A hydrometer measures the levels of chemicals in the dissolved solution and can be used to manage the zinc concentration levels in the footbath.

## Zinc disposal

Footbath solutions need to be changed when they become heavily contaminated.

Consider the disposal of footbath chemicals carefully. As zinc sulphate is a heavy metal and toxic to plants, take care to avoid contaminating pasture paddocks and water courses.

One way to dispose of footbath solutions safely is to pipe it into a properly constructed, covered, rubble-filled drainage pit near the footbath.

If waste zinc sulphate footbath is allowed to run down a surface drain or into a creek it will act as a herbicide, killing off the vegetation, leaving the area bare and dusty, and possibly causing erosion issues. Similarly, zinc run-off from sheep feet after they are released from the footbath will kill grass. Do not use sheep manure contaminated with zinc sulphate on gardens as it may act as a herbicide.

## Zinc – method of footbathing

Stand sheep on a hard surface or grating prior to footbathing if possible to help remove as much dirt as possible. This will help minimise contamination of the footbath.

Effectiveness will be improved by foot paring to expose any pockets of infection prior to footbathing.

Stand sheep in the footbath for the time recommended by the manufacturer of the product or as above. Footbathing is only successful if all the sheep's feet remain in the footbath chemical for the recommended length of time. Standing on a dry surface after 10 minutes of footbathing can increase effectiveness.

# Treatment

## Radicat

Radicat is a solution of copper salts used for footbathing. Any wool discolouration that may occur is claimed to be temporary and scours out naturally in 6–8 weeks. No withholding period is required.

Radicat claims protection against reinfection for up to two weeks.

Sheep are required to stand in the Radicat solution for at least 15 minutes then feet must be allowed to dry on grating for a minimum of one hour. Ideally, pare feet within four hours of footbathing.

Active ingredients do not strip out with use, separate, or settle on the bottom of the footbath.

Good cure rates can be expected but a number of footbathing sessions are required to achieve this.

Dispose of Radicat well away from a water course to avoid pollution and in a manner that meets all current regulations relating to chemical disposal.

Always wear personal protective equipment (PPE) when cleaning up a chemical spill.

As Radicat is corrosive, it is not recommended for use in metal footbaths. Radicat is best used in concrete, plastic or fibreglass footbaths.

## Formalin

Formalin was once widely used as footbath treatment for footrot and is still registered for footbathing sheep. Always follow label directions. Excessive concentrations or frequent use can make the skin between the toes brittle and crack, resulting in foot abscess.



**Take care:** Always wear personal protective equipment such as gloves and rubber boots when handling footbathing chemicals.

## Copper sulphate 10%

Copper sulphate has also been used in the past as a footbath solution, but the copper solution causes unscourable staining of the wool and hence is no longer widely used. It is corrosive so avoid use in metal footbaths. Effectiveness deteriorates significantly if the solution becomes contaminated with dirt and faeces. There are also concerns regarding copper contamination of the environment. Copper is toxic if too much is consumed by sheep or other animals.

## Antibiotics

Antibiotic injections are only available on prescription from a veterinarian. Accurate dosing and sound hygiene procedures are important. Always discuss any proposed use of antibiotics with your veterinarian.

Only inject infected sheep with antibiotics. Antibiotics only protect against new infections for a few days. Best results are seen when sheep are pored, footbathed, injected and kept on slatted floors for 24–36 hours after treatment. Following treatment and holding, move sheep to a dry paddock and then inspect them 3–4 weeks later. Cull any non-responders following treatment. Cure rates for sheep treated in this manner can exceed 90%. Hence antibiotics are recommended for use early during the summer non-spread period for eradication programs where too many sheep are still infected at the start of the non-spread period.

Footrot vaccines also can be curative – for more information read [Section 6. Specific vaccines.](#) 🗨️



**Environmental hazard:** Footbathing chemicals (such as zinc) can contaminate the soil surrounding the footbathing areas preventing regrowth of groundcover.

### Foot note

It is important to observe any withholding periods before sending sheep to slaughter. Several antibiotics are registered for treating footrot, but the best results appear to be after the use of long-acting oxytetracycline antibiotics.

# Footbath design and construction

## Key messages

- A footbath is essential on sheep properties where the flock is infected with virulent footrot.
- Well-designed, constructed and located footbaths increase the ease and efficiency of the footbathing process and the success of any treatment program.
- If possible, locate the footbath where sheep will not have to walk over contaminated ground after leaving the bath and yards.
- When calculating the size of the footbath, consider how long the sheep need to be in the footbath, as well as the number of sheep requiring treatment.
- A permanent footbath is best built of concrete. Where only benign footrot is an issue, portable footbaths may be more cost-effective.
- In a large concrete bath allow one square metre for three woolly, or four shorn, sheep.
- Locate the footbath close to a water supply and near to easy, but safe, disposal of used footbath solution.

A footbath is essential on sheep properties where the flock is infected with virulent footrot.

Even on uninfected properties, a footbath can help prevent footrot being introduced when sheep are bought in from elsewhere, or as an aid to prevent foot abscess in rams and pregnant ewes

### Siting the footbath

Ideally, locate the footbath where sheep will not walk over contaminated ground after leaving the bath and yards. Sheep should stand in a dry area, for example on slatted floor or in a concreted yard, for up to one hour after footbathing if possible.

Locating the footbath at the exit from the shearing shed means that after sheep have moved through the shed most of the mud and dung has fallen off their feet, providing better contact with the footbath solution and less contamination of the footbath. When sheep learn they will be sent back to the paddock soon after footbathing, they enter the footbath more readily.

Locate the footbath close to a water supply and near to easy, but safe, disposal of used footbath solution. Consider the disposal of footbath chemicals carefully as some solutions can be toxic to livestock, aquatic life and vegetation. It is best to run spent footbath solution through a pipe to an underground pit filled with rubble, where the solution can soak away.

If only one or two mobs of sheep on the property are infected, or benign footrot (scald) is the only problem, portable footbaths may be a better option than a permanent footbath if sheep can stand on a dry area following footbathing.

### Footbath design

When calculating the size of the footbath, consider how long the sheep need to be in the footbath, as well as the number of sheep requiring treatment.

Building a large footbath costs more up front, but is more cost effective in the long run for large numbers of sheep, due to the associated savings in labour costs, particularly where half to one-hour foot soaking is employed.

In a large concrete bath allow one square metre for three woolly, or four shorn, sheep.

#### Foot note



Sheep do not like stepping into water. Loading the sheep into the footbath can take a lot of time if effective sheep handling principles are not used. Designs where the sheep walk up an incline and then into the bath can hasten the process, as they don't see the water until they are in the footbath.

Side-by-side wide race designs, or designs where the sheep that have just been bathed are held just the other side in a draining pen, and are clearly visible, will 'draw' sheep into the footbath.

Be conscious of reflections off the surface of the water at certain times of day. It is worth building solid walls to avoid reflections. Get down low enough to see what the sheep are seeing and try to make them think that going the way you want them to is a way of escape.



**Clever design:** Designs where sheep can be drawn into the footbath by the presence of other sheep held in a yard at the end of the footbath make footbathing easier.

# Footbath design and construction

## Construction

A permanent footbath is best built of concrete. Obtain expert advice on cement content, the need for reinforcement mesh and general construction.

Baths may be constructed with either: a concrete floor and sides to a height of about 15–20cm, or a concrete floor and two layers of bricks for the sides. If using bricks, seal them with brushable sealant. Construct a yard around the bath using timber (most footbath solutions are corrosive to steel) with a gate at either end of the bath for sheep to enter and exit and a drain in the floor of the bath.

It is important the yard panels around the sides of the footbath are solid from the top of the wall of the footbath to a total height of 300mm above the floor inside the bath, and meet the top of the wall of the footbath at the inside edge to stop sheep resting feet on a ledge.

A concrete pen with a gate at least 1.5m wide appears to work best. It will generally hold more sheep and the sheep run into it more readily than a race bath. Sheep are also less likely to go down in the bath. Stand-in rather than walk-through baths are preferable, particularly when using solutions that the sheep must stand in for some time, as this type of bath allows larger numbers of sheep to be footbathed at once and allows for the correct stand-in times.

A roof over a footbath will reduce the chance of the solution being evaporated by the sun or diluted by rain. A bath under cover also may be easier to fill with sheep if it eliminates reflection on the water.

High-density foam, such as that used in foam mattresses, 10cm thick, placed in race-width footbaths will reduce splashing, save on footbath chemicals, stop sheep baulking at the water surface and stop sheep dogs drinking the solution. However, it can soon become damaged and pushed up one end of large baths. Foam lasts longer in race-type footbaths, and may be worth using while 'training' sheep to enter the footbath.

Cutting a section of weldmesh and laying it in portable metal or plastic baths will stop sheep slipping, but ensure there are no sharp edges that could cut the sheep's legs.

The depth of solution should be 5cm to 6cm (enough to cover the hoof). Solution soaking into the wool of the shanks is wasted.



## Calculating the volume of the footbath

Multiply length x breadth x height in metres to give volume in cubic metres (and then multiply by 1000 to give the capacity of the bath in litres).

1 cubic metre = 1000 litres

### Example

Length = 8m, breadth = 3m, height of chemical = 50mm (5cm or 0.05m)

Volume =  $8 \times 3 \times 0.05$  cubic metres  
=  $1.2\text{m}^3$  or 1200L

## Calculating the sheep-holding capacity of the footbath

Assuming that 3 x 60kg half-wool sheep occupy about  $1\text{m}^2$  of space, a footbath of  $8\text{m} \times 3\text{m}$  (i.e.  $24\text{m}^2$ ) would hold about 72 sheep (i.e.  $24 \times 3$ ).

See [Factsheet 8. Treatments](#) for information on footbath chemicals and footbathing protocols. 🐏



**Design considerations:** Stand-in rather than walk-through baths are preferable, particularly when using solutions that the sheep must stand in for some time, as this type of bath allows larger numbers of sheep to be footbathed at once and allows for the correct stand-in times.

Figures 2(a), 2(b), 3, 4(a) and 4(b) on the following pages outline the key common features of a range of footbath constructions.

# Footbath design and construction

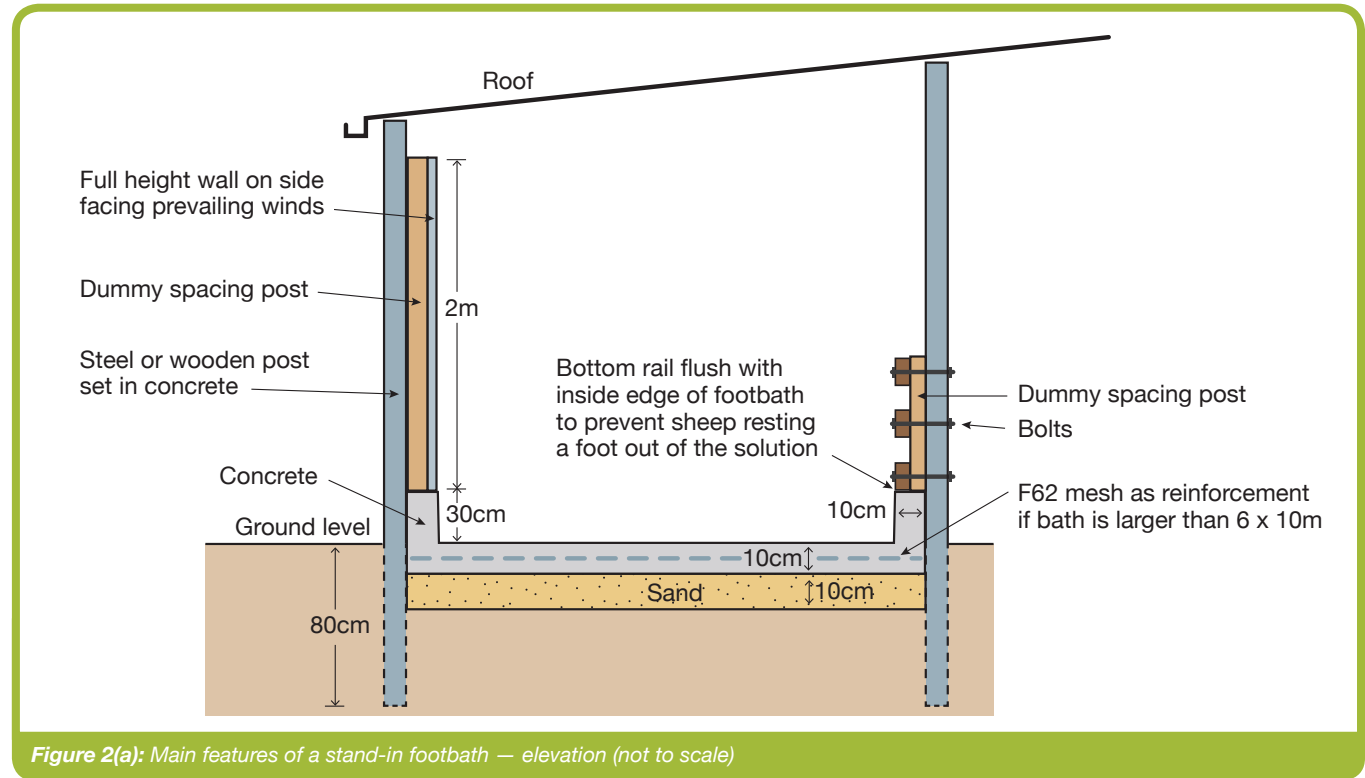

Figure 2(a): Main features of a stand-in footbath — elevation (not to scale)

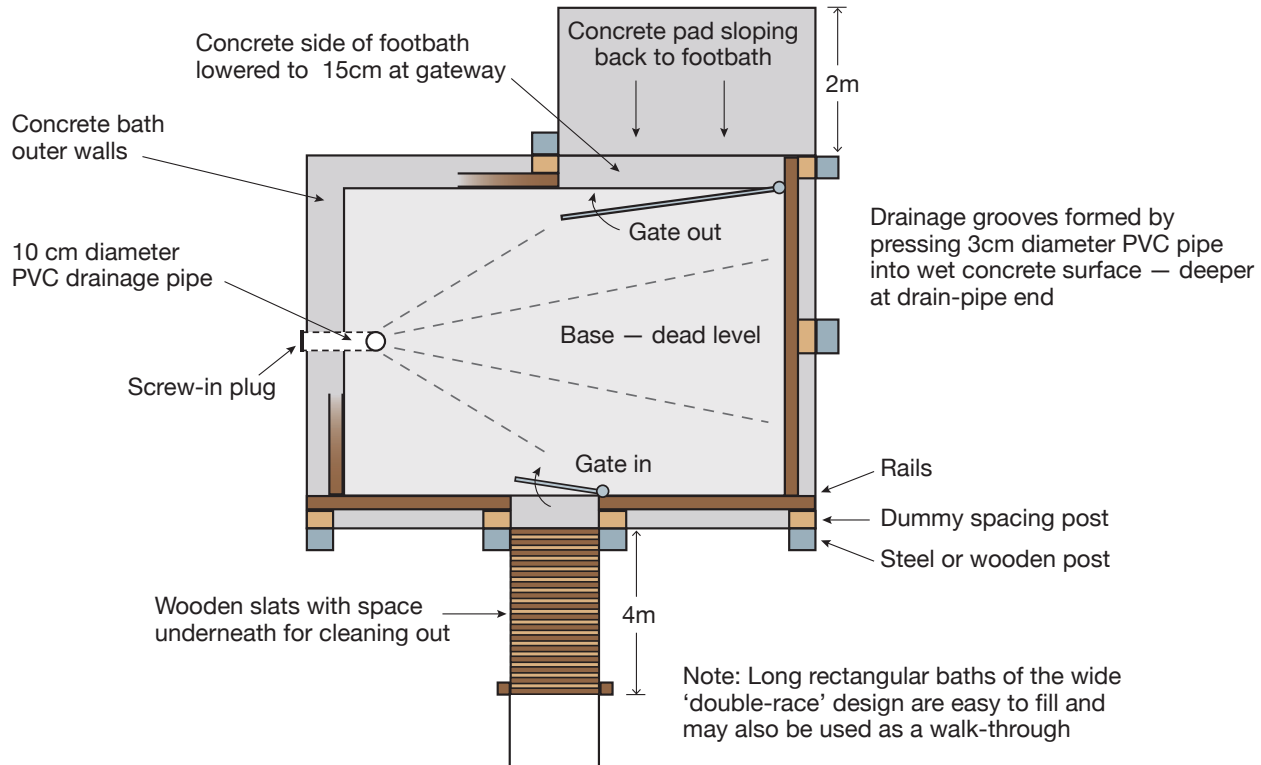
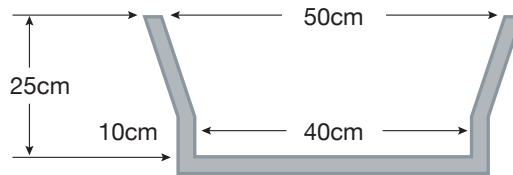

Figure 2(b): Main features of a stand-in footbath — plan (not to scale)

# Footbath design and construction



Slightly sloping sides

Flat sheets of galvanized iron bent and soldered at ends

Figure 3: Main features of a portable footbath — cross-section (not to scale)

Top view

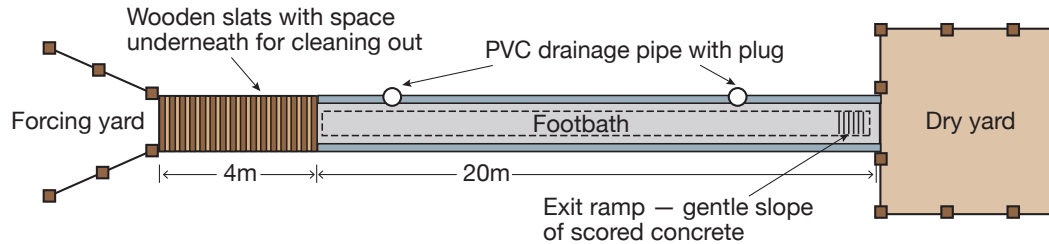

Figure 4a: Main features of a walk-through footbath — plan (not to scale)

Side view

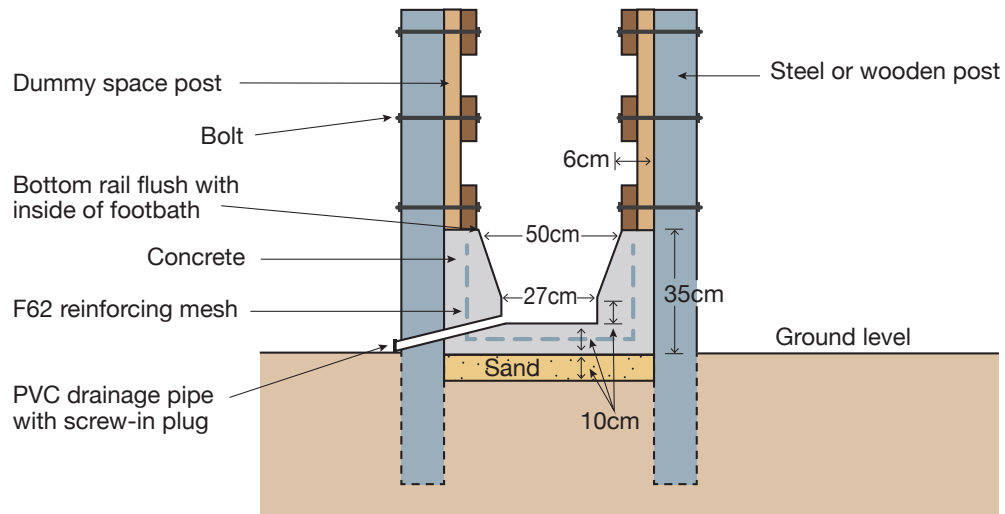

Figure 4b: Main features of a walk-through footbath — elevation (top) (not to scale)

# Surveillance and prevention

## Key messages

- Regular flock monitoring and proactive management are the keys to preventing the introduction of footrot.
- Ensure fences are secure and regularly monitor and repair any damage.
- Work closely with neighbours to develop a footrot prevention program — avoid neighbours ‘dropping’ strays back over the fence before they can be checked for signs of footrot and isolated from other sheep until they are deemed footrot-free.
- Manage the introduction of new livestock (including sheep, cattle and goats) carefully.
- Establish strict hygiene rules for visiting vehicles and foot traffic across paddocks.

If you have eradicated or do not have virulent or intermediate footrot, then you will want to prevent the disease becoming established on your property.

If you already have virulent footrot and may want to use specific serogroup vaccines in the future, it is important to stop new serogroups of footrot from infecting your flock.



**Under surveillance:** Regular monitoring and prompt action will ensure footrot is not reintroduced following eradication.

## Surveillance

The price of freedom is constant vigilance.

Regularly observe all sheep, especially in boundary paddocks and introduced mobs, especially during spread periods. Examine the feet of any lame sheep as soon as they are detected. Spray mark the sheep after examination to avoid examining again next time. If footrot is found, take measures to ensure infection does not spread to other mobs.

Also observe for 'strangers', isolate them and inspect their feet as soon as possible. Irrespective of the time of year, isolate the mob until you can diagnostically pare their feet. Actions will be determined by what you find in the strangers' feet and the time of year. If footrot is found and it is hot and dry, removal of the strangers may be all that is required. It is best to footbath and isolate the mob until a spread period has passed if possible.

### Foot note



If active footrot is found in strangers during a spread period, isolate the mob and implement control measures until you can carry out an eradication program. Alternatively, cull the whole mob.

## Fences and neighbours

Maintaining secure boundary fences is important, but trees can still fall over, gates can be left open, creeks can flood and fires can occur. Try to come to an agreement with your neighbours that they hold any of your sheep that stray onto their property and call you rather than drop your sheep back over the fence without your knowledge.



**Boundary security:** Ensure boundary fences are secure and repairs are carried out swiftly when damage occurs.

# Surveillance and prevention

## Introduced sheep

Treat all introduced sheep, including your returned strays, as suspect no matter where they come from — even rams from a trusted supplier of many years. Don't forget that poddy lambs, agisted sheep, goats and borrowed rams can all introduce footrot.

Ask the vendor to complete a Sheep Health Statement including section B1 on footrot before you introduce the sheep.

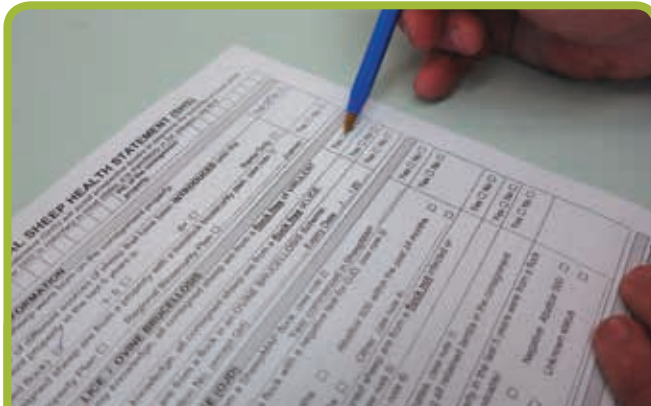

**Due diligence:** Always ask for a completed copy of the Sheep Health Statement from your vendor.

## Foot note



Unload introduced sheep into the yards or shearing shed when they arrive, immediately inspect all feet of all sheep, diagnostically paring where necessary. Footbath the sheep before isolating them for as long as possible, ideally in an irrigated or wet paddock with long grass until a spread period has passed without any breakdown.

## Feral goats

Feral goats often have little respect for fences and can be actively infected with virulent footrot. Eradicate such feral pests as soon as possible.

## Deer

Virulent footrot has been diagnosed in red deer in New Zealand, but surveys in Tasmania have failed to diagnose footrot of any virulence in fallow deer.

A number of properties in Tasmania have eradicated footrot and kept it out for many years in the presence of fallow deer. Fallow deer are not regarded as a high risk for spreading footrot.





**Introduced cattle:** Although the risk of introducing footrot with cattle is low, isolate any introduced cattle from sheep for 7–14 days during a spread period.

### Introduced cattle

Cattle can be infected with benign footrot, but rarely carry intermediate or virulent strains. Their hooves can be contaminated with virulent footrot bacteria if recently co-grazed with sheep infected with virulent footrot. Although the risk is low, it is best to isolate introduced cattle away from all sheep for 7–14 days if introduced during a spread period.

### Tyres and boots

Although the risk is low, it is ideal to have a rule that vehicles with potentially contaminated tyres do not drive over your paddocks during spread periods. Likewise, anyone who may have contaminated boots should change or clean and disinfect them before walking over your paddocks or yards during spread periods.

### Conclusions

Footrot can be kept out of your property, but stringent hygiene practices, especially with introduced sheep, must be built into management routines. 🌱



**Biosecurity:** Manage biosecurity with farm visitors by clearly setting expectations before they enter the farm.

# Case study — Saunders



Shelley Saunders and Chris Cocker well know the effort, cost and attention to detail required to eradicate footrot. After a two-year control and eradication program, which included regular flock inspections, foot paring, foot bathing and the use of antibiotics in severely affected sheep, the couple is declaring their flock footrot free.

“In January 2012 a bushfire destroyed half of our boundary fence and burnt several hectares of farm land around us,” Shelley said.

“Over the following couple of months we had stray sheep wandering on and off the property until the boundary fence was replaced around the end of March. During early April, we brought the sheep into the yards for crutching and noticed a few lame ewes. We turned them over to discover advanced footrot.”

“We’ve been here for 20 years and only ever experienced footrot once, about 10 years ago, with no sign of it since.”

“We were at a loss as to where the infection came from but thought the fire-damaged fence, giving stray stock access to our property, was the most likely source.”

## Farm information

**FARMER:** Shelley Saunders and Chris Cocker

**LOCATION:** Nile, Tasmania

**ENTERPRISE:** Ultrafine and superfine Merinos for wool and lamb production (about 2800 ewes)



**Strict biosecurity:** Footrot can be introduced in soil carried on boots, vehicle tyres and new or stray stock.

## Immediate action

Shelley and Chris needed a diagnosis as soon as possible to implement an appropriate management strategy. Chris contacted Department of Primary Industries Water and Environment (DPIPWE) Senior Veterinary Officer, Dr Bruce Jackson, who took some foot scrapings and confirmed virulent footrot, but not a specific strain.

Shelley and Chris immediately embarked on an inspection and control program, calling in contractors to turn over every sheep, inspect and pare every foot, and footbath every animal in zinc sulphate with sodium lauryl sulphate, and 20–30 animals with severe footrot lesions were immediately culled.

“At that stage we already had a footbath, but only a manual sheep handler, so we were not equipped to manhandle every sheep ourselves,” Shelley said.

“We thought if we got onto it quickly we would be right, but in hindsight we didn’t handle this early stage as well as we could have — we should have footbathed more frequently and sought advice from our consulting veterinarian earlier on.”

“During May and June 2012 we received 245mm of rain and by the time the contractors returned in June the affected sheep numbers had increased significantly to about 18% of the flock.”

“By this stage affected (dirty) sheep were identified in our clean mobs and half the dirty sheep presented as clean — but we had been so particular with footbathing, not crossing clean animals over contaminated ground that I knew something wasn’t right.”

Shelley called upon the services of local consulting veterinarian Dr Paul Nilon for his advice.

“Paul said there was no point trying to eradicate now (during winter), we had too many differential diagnoses due to the wet conditions — it was a waste of time,” Shelley said.

“So we chose to footbath during winter to contain the disease and try again to eradicate after spring.”

## Lambing management

One additional management change Shelley and Chris implemented in the meantime was to shorten their lambing period from five weeks to three.

“We wanted to restart footbathing as soon as possible after lambing during spring, so cut our usual five-week lambing period back by two weeks, which ended up being really effective. After the first footbathing (including 850 lambs) we only had two infected lambs.

“We brought the mobs back into the footbath every three weeks. It took so long to footbath with 50–60 in at a time, depending on the age of animals and their behaviour.”

## Summer eradication

Shelley and Chris decided against bringing the contractors back during the summer of 2013–14 to control costs.

“We decided to set ourselves up to do our inspections,” Shelley said. “We put down a 9m x 9m concrete slab, bought a Peak handler and two sets of pneumatic foot shears.”

# Case study — Saunders

“The handler was amazing — Chris set it up to fit the animals well, so they were relaxed and would lie in the cradle properly. In the end I got quite good at it, with just me and a dog. The first summer we had no roof and the sun was pretty harsh, but by the following summer we had erected a roof over the handling area, which made a huge difference.”

“We tried to eradicate in the one year — we started to foot pare not long after Christmas 2013 and raddled anything with score 1 or higher, though there weren’t many because of our vigilant winter–spring footbathing program.”

Shelley pared all four feet on every animal and continued to isolate clean sheep from dirty sheep, treating affected sheep with antibiotics and culling anything that didn’t respond.

“At the end of autumn we thought we had it beat — we hadn’t found any new cases, but we still had a small ‘active’ mob, which had been the treated animals we now considered clean.

Shelley’s cautionary approach paid off as the ‘active’ mob broke down in late November 2013. In January 2014 all sheep in the other mobs were inspected and found to be clean.

“After that point we didn’t footbath the clean ones again — we thought they were clean and if we were wrong we wanted the footrot to express itself.

Shelley treated the dirty mob again, but eased back on the footbathing to allow any footrot to express itself.



**Equipment set-up:** Contractors can be expensive and with the right set-up Shelley was able to inspect and treat her flock on her own.

“We culled the few with lesion score of 4 or more and treated the remaining with score 1 and 2,” Shelley explained. “We have been clean and free of footrot since March 2014.”

## Keys to success

According to Shelley footrot is the most challenging animal health issue she and Chris have had to manage to date.

“It is so disheartening to see it explode across the countryside,” Shelley said. “Eradication takes a lot of time, cost and dedication to detail.”

“It is so important to identify the disease and respond quickly. You need to know what you are looking for and ensure you keep clean sheep separate.”

Whether you embark on eradication or a control program depends on the time of year and your own enterprise goals, according to Shelley.

“Control is worthwhile, although treating is difficult,” she said. “When we had the outbreak the second year we kept a dirty mob and colour coded affected sheep. Anything that had been treated in the dirty mob was raddled so we could identify any escapees. Anything that didn’t respond to treatment was culled.”

Despite the expense and effort Shelley said she would take the same approach again.

“We would do the same thing because of the small flock size (2800) and focus of our enterprise — our genetic gains have been so great and we have so few animals out there for our niche market and to our mind they were worth the work and expense.”

Shelley admits that setting themselves up so they could carry out their own inspections was critical.

### Ongoing vigilance

Although they have seen no sign of footrot since early 2014, Shelley remains vigilant about monitoring their boundary fences and as soon as she finds neighbouring strays they are caught and inspected for any signs of disease (including footrot, lice and ill thrift).

“Fortunately stock straying onto our property since the outbreak has been during summer when it is dry. We always check any stray animals and sheep limping in the flock ” Shelley said.

“We also try to avoid dams and have established troughs as watering points in as many paddocks as possible to avoid muddy conditions, which can harbour footrot bacteria.”

According to Shelley the other useful tool was to have a pictorial guide\* to footrot scores: “sometimes early stage footrot is difficult to identify and to have a pictorial reference is really useful.” 🗨️

\*See [Section 2. Identifying footrot in the field — footrot score guide](#) on pages 10–12 for more information.



**Worth the effort:** Shelley and Chris have worked hard to build an ultrafine Merino flock and the effort to eradicate footrot has been worth it.

# Case study — Young



An vigilant control and eradication program, centered on a selective but severe culling approach, allowed Rae and Lindsay Young to control footrot in their 6000-head self-replacing Merino flock over a six-month period.

“During lambing three years ago (September–October 2012) we noticed a growing incidence of lameness in our four-year-old ewes,” Rae said.

“We had never experienced footrot at *Lewisham*, so the notion of an outbreak was totally unexpected and a complete shock.”

After inspecting the ewes Rae and Lindsay were convinced they had footrot and an inspection soon after by veterinarian, Dr Paul Nilon, confirmed it was virulent.

“Paul’s first piece of advice was to seriously consider changing our enterprise,” Rae said. “He told us it would be a long hard road to get rid of the problem — we chose to stick with our sheep and manage the footrot.”

Paul developed a program for the Youngs, which included both control and eradication phases.

## Farm information

**FARMER:** Rae and Lindsay Young

**LOCATION:** Ross, Tasmania

**ENTERPRISE:** Self-replacing Merino flock  
(6000 head)



“Control required footbathing the entire flock every two weeks until conditions dried off, when the eradication phase could start. This required thorough inspection of all feet up to four times and paring to confirm infection,” Rae said.

Paul advised against foot paring during the spring spread period, when the weather and soil conditions are warm and moist, as nothing would be gained. Footbathing every two weeks would control the spread until conditions dried off.

## Footbathing program

At the start of the control phase, badly infected mobs were still lambing, so Rae and Lindsay set up portable yards and footbaths in these paddocks.

“We bought eight plastic footbaths, which we placed in two rows, and treated ewes and lambs in the paddock,” Rae explained.

“Ewes spent 20 minutes in the footbath, and the lambs were treated separately for five minutes in plastic water troughs with a 40mm deep zinc solution. We placed a wire gate over the top of the race where the lambs were held to stop them from jumping out of the troughs. Bad affected ewes and lambs were treated with long acting antibiotics to relieve suffering.”

“The improvement was miraculous. We treated these mobs in the paddock twice before we were able to move them to the shed into the permanent footbaths where the rest of the sheep were being treated.”

According to Rae, the treatment that worked for them was a 20% zinc solution with sodium lauryl sulphate.

“Mobs spent a night in the shed emptying out, up to two hours in the footbath for adult sheep, 10 minutes for lambs (who were treated separately from their mothers) and one hour for hoggets. All sheep spent another night in the shed on grating to allow their feet to dry completely before returning to the paddock — this was critical to the success of the program.

“The first time we footbathed, we had to physically handle every sheep to get them into the footbath. The task of getting all 6000 sheep through the shed every two weeks seemed insurmountable.

“We were ready to toss it all in and living in town a long way from the nearest sheep seemed unbelievably attractive. Things did improve after this and our barking dog Lily was a tremendous asset. By the third round the sheep walked into the baths with no prompting.

“We learnt the hard way not to overcrowd the footbaths — make sure there is plenty of room so no one gets squashed. We held a maximum of 50 sheep in each footbath (9m long by 1.5m wide). For the adult ewes, we held 40–45 sheep on each side.”



Photos supplied by Rae and Lindsay Young

**Plenty of room:** Lindsay and Rae ensured sheep were not overcrowded during the footbathing process.

# Case study — Young



**Side by side:** Having two footbaths in the shed, side by side, with sheep held in a pen at the front of the footbaths helped to encourage animals to move into the zinc solution.

## From control to eradication

Rae and Lindsay stopped footbathing during mid-December, and embarked upon an eradication program in January — a month after the last footbath. This allowed them to more easily identify infected sheep.

“Before we embarked on the eradication process, which required footparing, we culled all the badly infected mobs (those with 40% infection), even though most sheep in these mobs were clean — they still posed the greatest risk which added up to 20% of the flock. They were cast-for-age and dry ewes and we did not inspect or footpare any of them and this saved weeks of work,” Rae said.

“Our fertility rate averages 120% so we could cull out as many as we needed,” Lindsay explained. “All culled sheep went to the meatworks, including sheep surplus to requirements, such as young ewes usually sold as breeders, which cost us income. However, this added up to about a third of our sheep saving a lot of work.”

“We bought a Peak Handler and turned over every sheep, inspecting and paring every foot and culled anything that was even vaguely suspect. We found one hogget out of 2500 and 30 suspect ewes, out of the remaining 2500, clearly with footrot.”

After the initial inspection and foot paring, Rae and Lindsay inspected the entire flock again a month later and the adult sheep four weeks after that.



“We inspected two times and if there was anything vaguely suspicious it just left the farm — went straight to the abattoir,” Rae said. “On the last inspection everything was clean and we haven’t seen any signs of footrot since.”

“The control and eradication process took six months, and all we had done in that time was manage footrot,” Rae said. “Many days we had footbathed from 8:00am to 10:00pm. It was no fun.”

### Precautionary tale

It is three years since the Youngs have seen footrot on *Lewisham*, but they would not be bold enough to say it has been eradicated. They have incorporated processes from their experience with the infectious disease that form part of a proactive preventative program.

“We footbath our lambing ewes before lambing every year as a key precautionary measure,” Rae said.

Rae and Lindsay are vigilant when it comes to introducing new rams to their property, footbathing every new animal, delivering a dose of long-acting antibiotics and holding the newcomers on feed in the shed for about 10 days before sending them to an isolated paddock.

Rae and Lindsay also agreed it was essential to have good communication with your neighbours and a collaborative plan to manage strays. 🌱



**Proactive approach:** Although Rae and Lindsay have seen no signs of footrot for three years they have taken a precautionary approach and still footbath their pregnant ewes before lambing each year.

# Glossary

**Benign footrot:** Benign footrot (also known as ‘scald’) usually only affects the skin between the toes regardless of the environmental conditions. Protease test negative, elastase test 20–28 days.

***Dichelobacter nodosus:*** the bacteria that causes all forms of footrot. There are many strains (or types) of *D. nodosus*, which vary in their ability to cause disease from mild *benign* to extremely *virulent*.

**Eradication:** Eradication is the elimination of all sheep and goats infected with virulent and intermediate strains of footrot from the property.

**Foot abscess:** Foot abscess is caused by *Fusobacterium necrophorum* (a bacterium that is ever present in the soil). Unlike footrot, foot abscess is not contagious (usually only a small percentage of the flock is affected) and usually only occurs in one digit, affecting one foot.

**Non-spread period:** Also referred to as non-transmission period. The non-spread period is when footrot does not spread from sheep to sheep — usually the hot dry summer and early autumn months in southern Australia.

**Orf:** Orf (often referred to as scabby mouth) can occur as scabs on the feet above the coronet. There is no involvement of hard or soft horn of the hoof. Orf usually self-cures in about three weeks — no treatment is required.

**Ovine interdigital dermatitis:** OID is an inflammation (reddening) of interdigital skin, usually of more than one foot, during warm weather, particularly when the pasture is lush or muddy. This condition is also caused by *Fusobacterium necrophorum* (the causal bacteria for foot abscess).

**Serogroup:** Footrot bacteria are grouped according to the antigen they contain — particular proteins in the fimbriae (small hairs) on the outside of the *D. nodosus* bacterium. The sheep’s immune system produces antibodies in response to these proteins, which are quite specific — the antibodies to one serogroup will not protect against another serogroup. There are 10 main serogroups — A to I and also M.

**Shelly toe (or shelly hoof):** Shelly toe occurs when there is a natural dry separation of the outside of the hoof horn near the point of the toe. A cavity forms between the horn and the hoof and this often fills with soil and dung. If infection is not present, paring of the outer wall over the shelly area and cleaning the dung and soil out of the cavity is all the treatment required.

**Specific serogroup footrot vaccines:** A specific vaccine is a custom-made vaccine that targets the serogroups of footrot present on any given property.

**Spread period:** Also referred to as transmission period. The spread period is a period when footrot spreads from sheep to sheep. Disease spread usually occurs when the average daily temperature is above 10 degrees Celsius, and soil conditions are warm and moist (usually in spring in southern Australia).

**Strawberry footrot:** Strawberry footrot is caused by *Dermatophilus congolensis*, the same bacterium that causes lumpy wool (scabs appear on the legs from the coronet to the knee or hock with hair loss). Removal of the scabs reveals a bleeding fleshy mass.

**Toe abscess:** Toe abscess most commonly involves front feet and results from damage to the hoof wall in the toe area. It occurs most often when conditions are wet and feet are overgrown. Toe abscess can be differentiated from footrot by laboratory tests.

**Transmission period:** See *Spread period*

**Under-running:** Separation of the hard horn of the hoof from the sensitive soft tissue underneath, resulting in severe pain and lameness.

**Virulent footrot:** Virulent footrot often causes severe under-running (except in goats) and spreads rapidly in warm moist conditions. Protease positive and elastase 4–12 days, usually IntA PCR positive. 🗨️

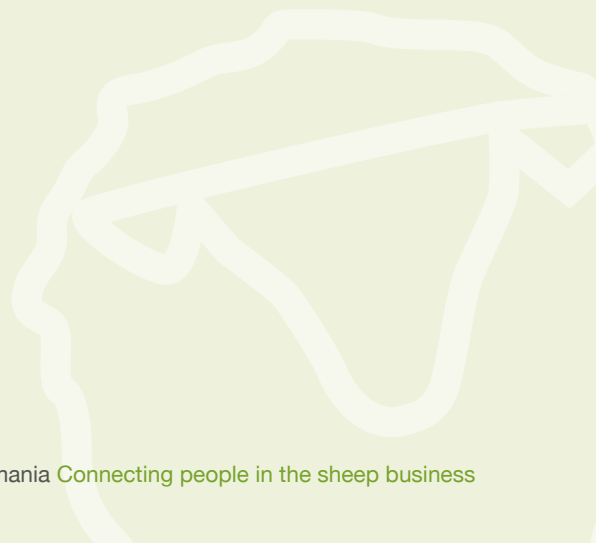



**For further information:**

Contact your veterinary practitioner  
or State Departmental Veterinary Officer.

**Sheep Connect Tasmania: [www.sheepconnecttas.com.au](http://www.sheepconnecttas.com.au)**



Australian Wool  
Innovation Limited



Tasmanian  
Government