



Australian Wool
Innovation Limited

MANAGING SHEEP IN DROUGHTLOTS A BEST PRACTICE GUIDE



CONTENTS

INTRODUCTION

Why establish a droughtlot?	3
Welfare requirements	4
Site selection recommendations	4
Construction options	7
Design	9
Farm profile	12
Death rates and culling rates	14
Key recommendations	15
Feeding of roughage	19
Animal health	20
How does lot feeding during drought effect wool quality?	22
Release of sheep after drought	23

CASE STUDIESS

Site selection	6
Construction	8
Design	12
Droughtlot management	16
Mob size	18
Animal health	21

MANAGING SHEEP IN DROUGHTLOTS

A BEST PRACTICE GUIDE

INTRODUCTION

The information in this publication aims to highlight the purpose, benefits and experiences of sheep producers managing sheep in confined areas during drought. The practice is commonly referred to under one of the following terms; feedlot, sacrifice area, containment area or droughtlot. Of these terms droughtlot is preferred because it is the most descriptive and has least emotive connotations. Droughtlot refers to the maintenance feeding of sheep in confined areas, primarily in order to minimise pasture and related environmental degradation.

Degradation of pastures during times of drought is of considerable concern to most sheep producers. Soil degradation and low pasture productivity post drought are common costs associated with periods of drought for sheep producers. In the past, drought management practices have involved leaving sheep on pasture where they are supplementary fed. But this practice often results in a loss of productive pasture species, particularly the perennial component, and a reduction in soil fertility due to erosion.

The practice of confining sheep in small areas at high stocking rates in order to minimise the degradation of soil and pasture resources started in the 1980s. This approach emerged in the face of changing community attitudes towards environmental degradation and increased awareness of the role of perennial pastures in sheep production.

This book provides guidelines on establishing and managing a droughtlot. It is based on a combination of sheep producer experiences and a survey of droughtlot practices in the 2002/03 drought.

WHY ESTABLISH A DROUGHTLOT?

One of the most important issues for any farm business emerging from drought is the need to restore the business to optimum productivity and profitability as quickly as possible. The purpose of the droughtlot is to assist this specifically by:

- Preserving preferred pasture density or composition.
- Minimising soil and nutrient loss from bare ground.

There is a short term cost associated with confining sheep because once confined the ration has to be increased to compensate for the lack of pasture intake. Even in what appears to be bare paddocks, sheep will usually gain some benefit from the pasture. This cost can be significant, for example if confined and fully fed a sheep may consume an extra 1kg/head/week for eight weeks, compared to a sheep supplemented at pasture. At \$300/t for grain, the additional feed cost incurred from confining the sheep is \$2.40. However if we consider this as a per hectare cost it would be as shown in Table 1.

The additional cost per hectare is relatively small compared to the investment in soil, fertility and pastures. When considering the cost of damage to soils and pastures, keep in mind:

- Pasture
 - Re-establishment costs, often around \$300 per hectare.
 - Lost grazing from paddocks while pastures are re-established.
 - Reduced productivity of pastures until the more productive pastures are re-established. It will take 10-20 years if pastures need to be re-established on the whole farm.

TABLE 1: Feed costs for a range of stocking rates.

STOCKING RATE (SHEEP/HECTARE)	ADDITIONAL FEED (COST/HECTARE)
5	\$12
10	\$24
15	\$36

MANAGING FODDER PRICES FOR DROUGHTS

A SHEEP PRODUCER'S GUIDE



Droughtlot refers to the maintenance feeding of sheep in confined areas

- Loss of soil nutrients
 - If a drought results in substantial pasture and soil damage, the cost of the damage can exceed many fold the cost of additional feed.

There are numerous factors and strategies sheep producers should consider and ensure prior to establishing a droughtlot facility. These factors can influence the effectiveness and efficiency of the operation and in turn save or cost the farm business valuable income and resources depending upon how they are developed, implemented and subsequently managed.

WELFARE REQUIREMENTS

The recommendations from the model Code of Practice for the Welfare of Animals - the Sheep (Anon 2006) which relate to lotfeeding sheep during drought include:

- Minimum space allowances (Table 2).
- Ad lib group feeding requires a minimum of 2cm of trough space per head. If fed less at set feeding times, allow up to 20cm of trough space per head to allow all sheep to feed at the same time.
- A minimum of 1.5cm of water space per head.
- Attention should be given to identification and treatment of shy feeders.

TABLE 2: Minimum space allowances.

	M ² /HEAD	SHEEP PER HECTARE
Lambs up to 41kg	1.0	10,000
Adult sheep	1.3	7,700
Heavy wethers (fat score 5)	1.5	6,670
Ewe & Lamb(s)	1.8	5,550

SITE SELECTION RECOMMENDATIONS

Establishment of a droughtlot need not be an expensive exercise. However, if possible aim to use existing facilities or if additional facilities need to be constructed try to ensure that they can be useful in non-drought years. On most farms the droughtlot should be able to be incorporated into existing infrastructure to reduce the cost and increase the return.

Factors to consider are:

- Drainage.
- Shelter.
- Convenience to facilities.
- Reliable access to adequate quality water supply.
- Minimum distance from water storages and water courses.

FIGURE 1: Possible pen layout option with slope to allow for run off

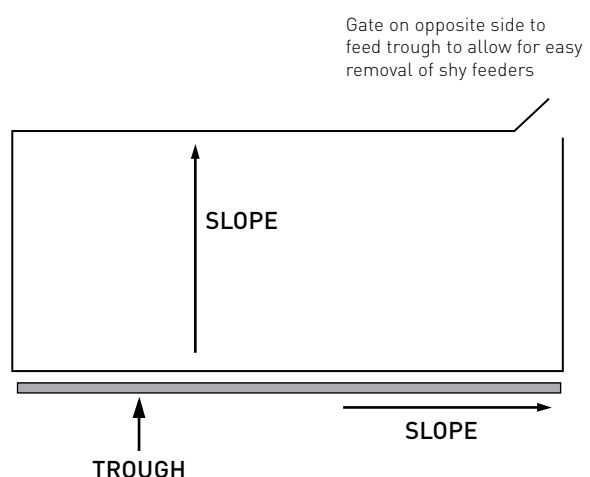

The alternative to establishing a specific facility is to use a 'sacrifice' paddock. This can be a degraded pasture paddock that is scheduled to be grazed or renovated. Alternatively, it could be a stubble paddock which has the advantage of a yearly supply of roughage and straw which is useful in preventing soil loss from either wind or water.

The disadvantage of using existing paddocks is that the whole paddock can become bare and subject to damage versus a small area affected if sheep are more confined. Also if mob sizes are not too large, for example if weaners and ewes need to be kept separate, a number of paddocks may need to be sacrificed which again increases the area of potential damage.

DRAINAGE

Sloping stable soil is preferred to level ground to allow run off, to ensure vehicle access to the droughtlot after periods of rain and to avoid bogging (Figure 1).



Trees that sheep have access to will need to be protected to avoid ringbarking

SHELTER

Shelter is not necessary though if available it can be incorporated into a droughtlot. Any trees that sheep may have access to will need to be protected to avoid ringbarking.

CONVENIENCE TO FACILITIES

Considering the amount of time required to feed, clean and monitor, it is important to make the droughtlot as close as possible to essential facilities, including fodder storage and sheep handling facilities.

ACCESS TO A RELIABLE SUPPLY OF ADEQUATE WATER

Watering from dams is largely discouraged due to the risk of the water supply drying up or becoming contaminated (with soil and/or dung) following heavy rain. Troughs are generally the preferred option. A large amount of trough space to provide simultaneous access for a large number of sheep is not necessary. Sheep will take turns drinking; high flow rates are more important to ensure rapid replacement of water levels.

MINIMAL DISTANCE FROM WATER STORAGE AND WATER COURSES

A minimum distance of 500m from water storages and water courses is recommended to avoid contamination. Alternatively, a nutrient filter can be located on the down slope side of the area. Contour banks can assist above and below the droughtlot to minimise water running on and off the site.

PRIVACY

Locate droughtlots away from houses and public roads.

SITE SELECTION CASE STUDY – SEE PAGE 6

An overview of considerations for site selection as employed by one farm operation in the Southern Tablelands region of New South Wales is provided in Case Study 1. The sheep producers in this instance had experience with droughtlots over two consecutive drought periods. The site selected was intended to support approximately 3,500 mixed age ewes and 1,000 wether weaners.

SITE SELECTION

CASE STUDY 1

Case study 1 provides an overview of considerations for site selection as employed by one farm operation in the Southern Tablelands region of New South Wales. The sheep producers in this instance had experience with droughtlots over two consecutive drought periods. The site selected was intended to support approximately 3,500 mixed age ewes and 1,000 wether weaners.

FARM PROFILE

Location:	Southern Tablelands NSW.
Area:	1,200 hectares.
Long term rainfall:	625mm but only 225mm in 2002.
Pastures:	Mixture of improved perennials, annuals and some native pastures.
Enterprises:	Self replacing Merino flock, selling surplus sheep and Dorset x lambs.
Management:	August lambing. November shearing.

FACILITY

The droughtlot was based on yards built around existing holding yards, a set of sheep yards and a shearing shed. The associated cost of the facilities was low because they were incorporated into existing infrastructure.

FEATURES OF SITE

- Existing fence lines can be used for one or more sides to minimise costs.
- Ring lock or hinge joint held up by steel posts is commonly recommended.
- Whether the facility is a temporary or permanent fixture can influence the quality of the construction.

CASE STUDY 1 - Pen layout based around existing sheep yards

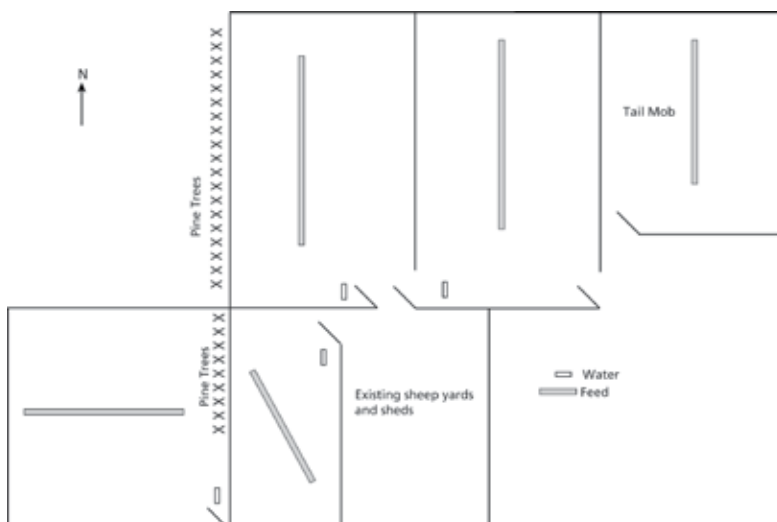

CONSTRUCTION OPTIONS

Recommendations for construction

- Existing fence lines can be used for one or more sides to minimise costs.
- Ring lock or hinge joint held up by steel posts is commonly recommended.
- Whether the facility is a temporary or permanent fixture can influence the quality of the construction.
- Merinos do not require fencing of the standard used for normal farm fences, which helps to minimise cost. More robust facilities are required for British breeds and their crosses.

CONSTRUCTION CASE STUDY – SEE PAGE 8

An example of construction methods undertaken by one farm in the Southern Tablelands region of New South Wales is provided in Case Study 2. The sheep producers in this example had no previous experience in establishing a droughtlot facility. The aims of this particular droughtlot were to:

- Keep options open.
- Protect the land.
- Maintain stock numbers after the drought.



Existing fence lines can be used for one or more sides to minimise costs

CONSTRUCTION

CASE STUDY 2

Case study 2 provides an example of construction methods undertaken by one farm in the Southern Tablelands region of New South Wales. The sheep producers in this example had no previous experience in establishing a droughtlot facility. The aims of this particular droughtlot were to keep options open, to protect the land and to maintain stock numbers after the drought.

FARM PROFILE

Rainfall:	Average 500mm per annum.
Enterprises:	Merino flock and cattle.
Management:	October shearing. Mid June lambing.

CONSTRUCTION

The droughtlot consisted of four holding pens 75m wide by 100m deep. In front of these were two feeding pens each 30m x 230m. It took approximately one month to construct the droughtlot to hold 6,000 sheep.



Existing fence lines can be used for one or more sides to minimise costs



Recycling or using existing infrastructure is recommended

Feeding pens were constructed separate to holding pens.

Fences were constructed of creosote posts at 10m spacings and a dropper in between. Sheep and lamb cyclone was used on all except the high pressure areas. Around the outside of the droughtlot a plain wire was added on top. High pressure areas had 1m high pig cyclone (approx 15cm mesh). Gates were 2 x 10m for each pen.

A handling facility was built in the corner of one of the feeding pens.

CONSTRUCTION

- Cost of materials was \$10,000.
- Materials included one water tank and four troughs, posts and cyclone.
- Labour to install was around \$5,000 which equates to \$4.50 per sheep.
- The facility will be used again.

DESIGN

There is no standard for design of droughtlots however the three most commonly used designs feature on pages 9-11. The advantages and pitfalls of each design are specified.

OPTION 1: SEPARATE FEED YARD

Hay is fed in the holding yard while grain is fed in the feeding yard. Sheep are kept in the holding yard except on feeding days (Figure 2).

PROS

- Avoids the need for troughing for each mob.
- Grain can be fed out in a pen without sheep being present, which makes it easier than driving through the mob of sheep.

PROS

- Requires feeding of hay and grain to at least one mob every day, even if each mob is fed 1-2 times per week.
- Additional fencing and gates compared to Option 3.
- Increased risk of diseases associated with contamination of site, e.g., salmonella, coccidiosis.

FIGURE 2: Separate feed yards

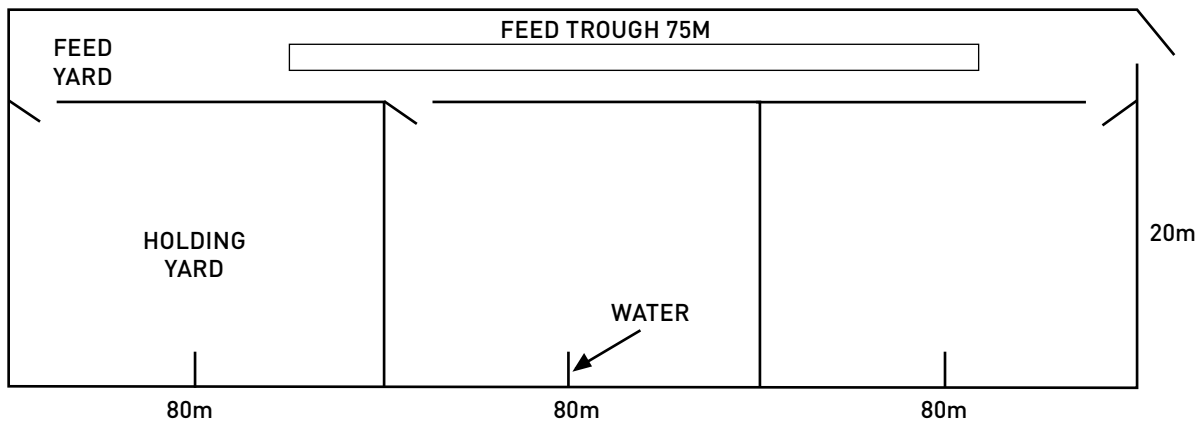

Source: Feeding Sheep PIRSA (1997)

OPTION 2: EXTRA PEN ROTATION

The design is based on having one more pen than mobs of sheep (Figure 3). This enables sheep to be fed in empty pens and then stock let in. Grain is fed first in the empty pen then stock moved in. Feed is then put out in the next pen and stock moved in and so on. At the next feed the process is reversed with feed put out without stock present in the pen.

PROS

- Feed can be put out in empty pen.
- All yards can be fed on the same day.

CONS

- Feed and water troughs required in each pen increases cost.
- One more pen required than number of mobs being fed.
- If pens are small it does not enable one length of troughing when following standard recommendations of 15-20cm of double sided trough per 100 head.
- Sheep rushing through gates to feed can be a problem. They appear to improve with time.

FIGURE 3: Extra pen rotation

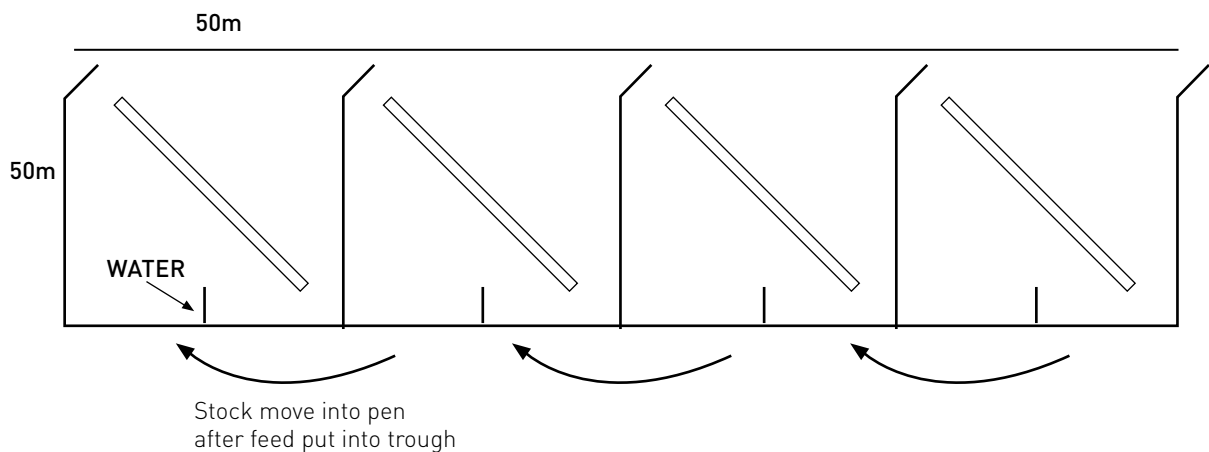

OPTION 3: ONE YARD PER MOB

This design provides one yard per mob to be confined (Figure 4). The capital cost is minimised but feeding can be more difficult unless fed from the outside of the yard.

PROS

- Minimise fence length and therefore cost.
- All yards can be fed on the same day.
- Troughing outside the yard makes feeding easy and a one person job.
- Troughs outside the yard minimise the risk of disease due to site contamination, e.g., salmonella, coccidiosis.

CONS

- Feed is put out while sheep are in pens, increasing the chance of sheep escaping or moving between pens.
- May require two people to feed out.
- Troughs outside the yard doubles the length of trough required because sheep can only get access to one side. Also requires a system that delivers feed from the side of vehicles.
- Small pen sizes do not enable one length of troughing in the pen when following standard recommendations of 15-20cm of double side trough per 100 head.

FIGURE 4: One yard per mob

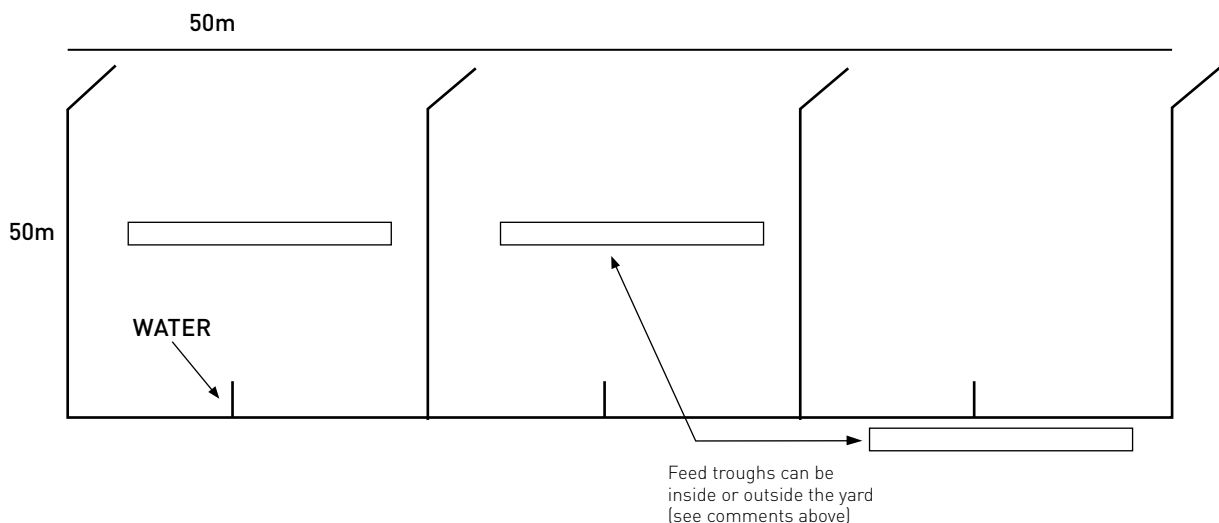

CONSTRUCTION

CASE STUDY 3

An overview of the design of a droughtlot facility in southern NSW is provided in Case Study 3. The sheep producers in this instance were experienced in droughtlot management having used them previously, in the droughts of 1994 and 1997. Important lessons in design from the earlier years were transferred and expanded upon to result in a highly functional and practical lot system.

FARM PROFILE

Area:	1,880 hectares in four different blocks.
Rainfall:	Long term average 800mm but only 587mm in 2002.
Pastures:	80 per cent of country sown down to perennials.
Enterprise:	Self replacing fine wool (18.5 micron) Merino flock of 12,000 ewes, 8,000 wethers and 4,500 weaners.

DROUGHTLOT DESIGN

- Aim to stock at 5,000 – 6,000 per hectare.
- To avoid opening gates and minimise feeding time, always feed from the outside of the droughtlot (using a side delivery system).
- Gates should be on the opposite side of the pen to the feed troughs to make removal of shy feeders easier.
- Construct pens as part of existing facilities wherever possible to ensure they can be used at other times.

CASE STUDY 3: Fence and feed trough system

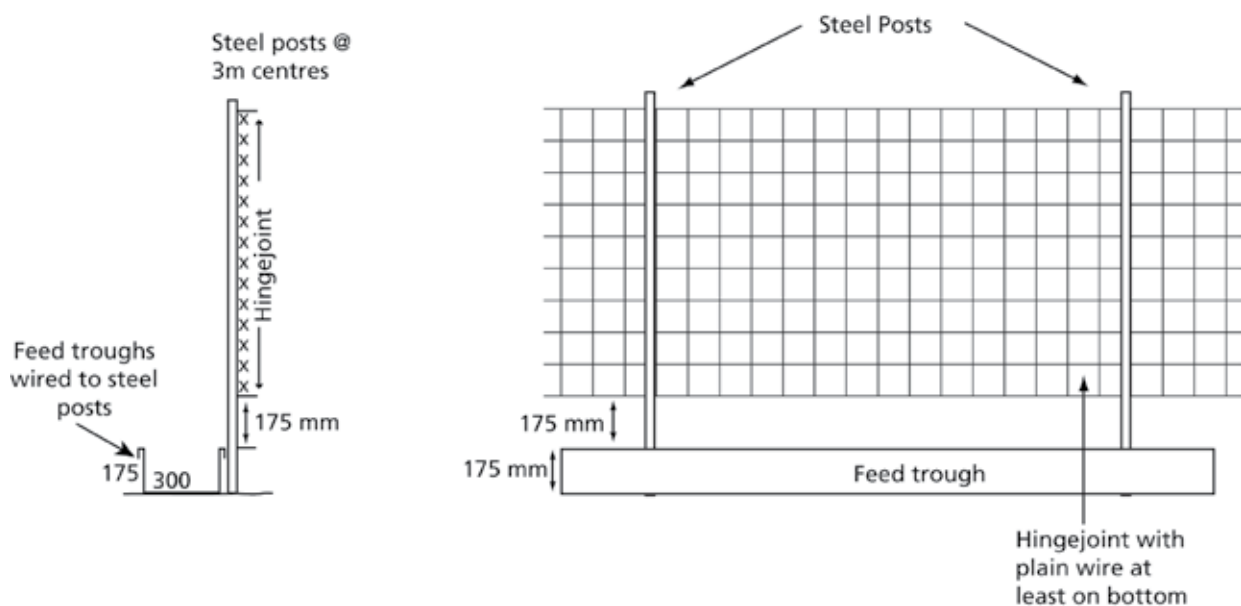

FEED TROUGHS

Provide 5cm of trough space per head.

Trough capacity must be at least 1.5kg per head. Troughs were rectangular running down the long side of the pen.

Locate feed troughs on the top side of the droughtlot so run off moves away from the trough. A number of different types of feed trough were used, including:

- Conveyer belt with fence in the middle. The main problem was sheep could stand in them so they needed regular cleaning but they were also slow and therefore expensive to construct. Belting cost increased to \$12 per metre during the drought.
- To overcome the problem of contaminating the troughs, belting was tied on the outside of the fence with the fence high enough off the ground to allow sheep to feed underneath. This was not satisfactory because the belting was too wide and sheep could not reach all the grain. Also there was the occasional tyre spiked on the cut off steel posts used to support the belting.
- The third and successful option was to use metal feed troughs on the outside of the fence with a 175mm gap between the top of the trough and bottom of the fence. Troughs cost approximately \$11 per linear metre and will need to be stored inside when not used. They are much easier to handle than belting.



Feeding from outside pens requires a side delivery system
©CSIRO Plant Industry



Provide 5cm of trough space per head
©CSIRO Plant Industry

- Provide 5cm of trough space per head. Provision of at least 5cm of trough space per head was obviously insufficient for all sheep to feed at once but all seemed to have sufficient access. Those mobs with more trough space had no more tail than those with the minimum 5cm.

LESSONS LEARNED AND THINGS TO CHANGE

- Incorporate the facilities into the design of your existing yards wherever possible.
- Ensure the water system is right from the start.
- Feed lime from small troughs in the pens, not through the feed-out cart because it affects the flow rate of the grain.
- Locate feed troughs on the top side of the droughtlot so run off moves away from the trough.
- Water supply must be good – it is easier to move the sheep and the grain to water than vice versa.

DEATH RATES AND CULLING RATES

There is a wide variation in death rates in droughtlots. Surveys in South Australia showed an average of 1.8 per cent and 1.4 per cent in 1982 and 1988 respectively. An AWI survey found an average of 2.8 per cent and a median of 1.4 per cent. The distribution of deaths is shown in Table 3.

The main point to note from these results is that the majority of sheep fed in droughtlots had quite low levels of mortality and much lower than the potential death rates if sheep were not supplementary fed during drought. However, there were a few which experienced high death rates for a variety of reasons.

Table 4 outlines causes of mortality as recorded in the AWI commissioned survey. The data reveals acidosis and tail end sheep, which were responsible for 85 per cent of total deaths in droughtlots during the 2002/03 drought period, as the more important causes of death.

TABLE 3: Percentage of farms by death rate

DEATHS	1982	1988	2002/03
0-1%	60%	65%	70%
1-2%	18%	10%	16%
2-3%	8%	10%	4%
3-4%	5%	10%	2%
>4%	11%	5%	8%
	(Ashton & Hannay 1984)	(Morbey & Ashton 1990)	(AWI/HSA 2003)

TABLE 4: Causes of mortality

CAUSE	%
ACIDOSIS	48
TAIL END*	37
ACCIDENTAL	3
UNKNOWN	16

* Poor condition

Source: Holmes Sackett & Associates

Implement a number of management practices to minimise the risk of deaths, including:

- Introducing grain according to recommended schedules prior to introduction to the droughtlot if possible.
- Removing shy feeders prior to entry and whilst in the droughtlot. If there are high stocking densities or if there is a tail appearing in the mob, this should be done at least every two months and more frequently in larger mobs.
- Feeding roughage.
- Ensuring sheep are properly vaccinated against clostridial diseases.
- If possible avoid running young sheep in droughtlots.
- Sheep rushing through gates to feed can be a problem. They appear to improve with time.

KEY RECOMMENDATIONS

Following the 2002/03 drought, AWI commissioned a survey of sheep producers who managed sheep in droughtlots. The survey was undertaken to collect some basic information on the performance of sheep in droughtlots and to identify any factors that were an important influence on the survival of sheep.

Participants were predominantly from New South Wales and Victoria with a small number from South Australia. A total of fifty sheep producers were involved in the survey and, allowing for the fact that many had more than one management group, a total of 125 different droughtlots were surveyed.

The average and range of results is set out in Table 5.

Based on the results of the analysis there were a number of factors that were shown to influence the performance of sheep in droughtlots. These factors provide a basis for setting up and managing sheep in confined areas but they are a guide only. In a number of instances the management program can be varied considerably. This applies particularly to mob sizes.

STOCKING DENSITY

The recommended stocking density is approximately 2,000 sheep per hectare. In the survey, higher stocking densities tended to be



Higher stocking densities than 2,000 sheep per hectare tended to be associated with higher mortality rates and poor doers

TABLE 5: Average and range of results from AWI droughtlot survey 2002/03

	AVERAGE	RANGE
TIME ON FEED (DAYS)	136	41-407
STOCKING DENSITY (SHEEP/HECTARE)	1,210	2-9,862
MOB SIZE (NUMBER OF SHEEP)	1,214	22-12,222
SUPPLEMENTARY FEEDING PRIOR TO ENTRY (WEEKS)	6.8	0-40

DROUGHTLOT MANAGEMENT CASE STUDY – SEE PAGE 16

An example of droughtlot management methods adopted on one farm located in central New South Wales is provided in Case Study 4. This example highlights the importance of creating a plan of action and schedule based on key strategies for selling and feeding.

associated with higher mortality rates and poor doers. This is particularly important if roughage is not going to be fed, because high stocking densities without roughage are associated with a substantial increase in poor performance. Very low stocking densities also tended to be associated with poor sheep performance, possibly because of inadequate access to feed. Also low stocking densities result in more country being damaged, which to some extent defeats the purpose of a droughtlot.

Many mobs have been run at stocking densities well over 2,000 sheep per hectare with one of the objectives being to minimise dust. At high stocking densities of around 5,000 sheep per hectare the urine and dung may be more likely to form a hard pad, which minimises the problem with dust and even mud. Whether or not a hard pad forms seems to be more dependent on soil type than stocking density with some soils not packing hard regardless of stock density.

One advantage of higher stock densities is that less infrastructure is required for a given number of sheep.

DROUGHTLOT MANAGEMENT

CASE STUDY 4

Case study 4 provides an example of droughtlot management methods adopted on one farm located in central New South Wales. This example highlights the importance of creating a plan of action and schedule based on key strategies for selling and feeding.

FARM PROFILE

Location:	Central NSW.
Area:	1,400 hectares.
Rainfall:	Long term average 800mm.
Pastures:	1,000 hectares sown to improved pastures.
Enterprise:	7,000 Merino sheep and a 500 head self replacing beef herd.

STRATEGY

The most important factor in the whole lot feeding program was writing down the sell or feed strategy. The sheep producers wrote down dates at which time key actions were to be undertaken if rain had failed to arrive in spring 2002. These dates were cast in stone.

DATE	ACTION
1 August	Ring the stock agent and sell 1,350 older wethers.
1 September	Draft off any cull ewes and sell. Accept the market price. Plan feed requirements for the next 8 months and consider locking in a feed grain contract. Assess cattle feed available and sell any trade animals that are ready. Do not be greedy.
1 October	Start introducing wheat rations. Start building feed pens. Check on feeding equipment (augers, silage carts etc). Have all feed on hand tested for quality.
1 November	Start moving sheep into pens.

By acting early a good price was obtained for sale wethers and cull ewes, and while target dates slipped a bit, sheep were taken off the paddocks before any serious damage was done to pastures. The program was not deferred just because rain looked likely at the time.

Lambs were weaned earlier than usual. They were all trained to feed on grain while on their mothers, and were fed a lupins/wheat mix. The plan was to rotate lambs around the several paddocks to utilise any available green pick from summer storms.

The tail of each mob was drafted off before droughtlot entry and then regularly during lot feeding.

The advantages achieved from lot feeding that are considered important were:

The preservation of pastures. Having undertaken extensive pasture improvement over the past eight years the sheep producer wished to protect the capital investment.

Any available green feed from summer storms can be utilised by lambs. No plan was ever made to lot feed lambs because they had many more paddocks available on which to be grazed.

Ease of feeding stock. It is quicker and more efficient to feed stock in pens.

Shy feeders were able to be identified, easily separated and fed preferentially.

MOB SIZE

The optimum mob size is less than 1,000 head. There is no benefit in having smaller mobs, so mob sizes up to 1,000 should be determined more by logistics (e.g., number in age groups or classes). Mob size can be increased if necessary but it will be likely that additional management will be required to identify and remove tail end sheep. Mob sizes should not exceed 2,000 head because it presents an increased risk of progressively higher mortality and culling rates particularly when sheep are fed on the ground. If large mob sizes are needed, it is preferable to feed sheep in troughs (Graph 1).

MOB SIZE CASE STUDY - SEE PAGE 18

An example of feeding practices, costs and lot designs for a large number of smaller mobs located on a farm in central Victoria is provided in Case Study 5. The practice of feeding the mobs on the ground rather than in troughs worked well in this instance.



The tail end of the mob should be removed at least every two months ©CSIRO Plant Industry

GRAPH 1: Interaction between mob size and mortality

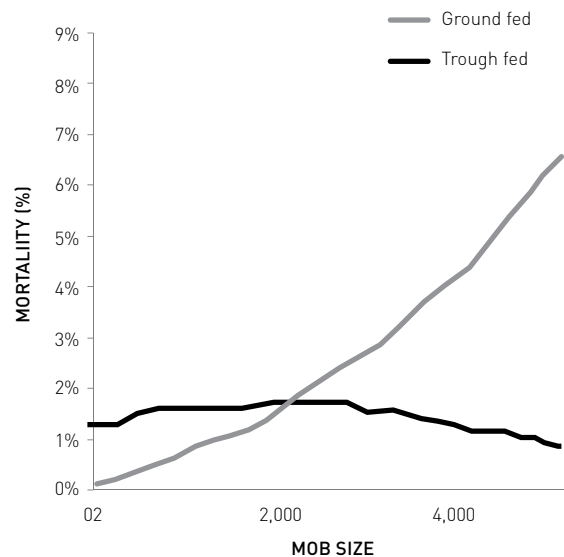

TAIL MANAGEMENT

The tail end of the mob should be removed at least every two months, particularly if mob sizes are in the range of 1,000 to 2,000 head. Failing to do this will increase the risk of deaths. Poor doers may need removing more frequently in the early stages, though these may not be very obvious if sheep are in good condition on entry. An area designed like that in Figure 1 allows easy identification and removal of shy feeders because they do not move across to the feed.

Factors which contribute to a large tail in the mob include:

- Feeding grain only without roughage (see separate section on roughage).
- High stocking densities (greater than 2,000 sheep per hectare).
- Very low stocking densities.
- Mob sizes which exceed 1,000 head.

If you have any of these factors in the droughtlot be prepared to remove the tail of the mob more frequently to minimise the number of tail end sheep that die.

MOB SIZE

CASE STUDY 5

Case study 5 provides an example of feeding practices, costs and lot designs for a large number of smaller mobs located on a farm in central Victoria. The practice of feeding the mobs on the ground rather than in troughs worked well in this instance.

FARM PROFILE

Location:	Central Victoria.
Area:	4,200 hectares.
Rainfall:	525mm rainfall (325mm in 2002).
Pastures:	80 per cent improved pastures phalaris and sub clover.
Enterprise:	Self replacing merino flock of 12,000 Merino ewes and 8,000 Merino weaners. Clip average 19.5 micron. 400 hectares crop (to provide feed for sheep).
Management:	April shearing, July-August lambing.

GENERAL DROUGHT MANAGEMENT STRATEGY

The general drought management strategy was to sell cast for age stock and wethers early and retain the core breeding flock.

Early sale of surplus stock started in August.

18 month old wethers were sold in August (normally November).

All ewes were wet-dried in September and 2,000 dry ewes (except maidens) were shorn with 5-6 months wool and sold.

All five and six year old broken mouth ewes were sold in October after weaning. All five year old ewes are normally retained.

All wether lambs sold (normally some retained to 18 month old).

The plan was to run 11,000 ewes in droughtlots (nine pens) and the remaining 5,000 ewe and ram weaners in paddocks.

Droughtlots were set up strategically beside silage pits. Stock were removed from paddocks to droughtlots once ground cover reduced to 80 per cent.

DROUGHTLOT FACILITIES

A total of nine pens were set up to carry about between 1,100-1,200 sheep each.

Pen dimensions were 85m x 60m for four pens designed to carry about 1,000 sheep (4.5-5.1m² per sheep). See diagram below.

At a separate site, five pens had a dimension of 160m x 50m designed to carry up to 1,600 sheep (5m² per sheep). Each site was selected due to proximity to silage pits. Each pen had a water trough which was fed from the one water line to reduce capital costs.

Both silage and grain was fed to sheep on the ground in pens. It was possible to feed sheep from the outside of pens.

However, with large sheep numbers the pens were not long enough to feed so a trail of silage was fed on the ground about 480m long in the pens. Rectangular pens enabled longer feed trails to be fed. There were no problems observed from feeding on the ground in pens, minimal wastage and a pad quickly developed that ensured dust was not a problem.

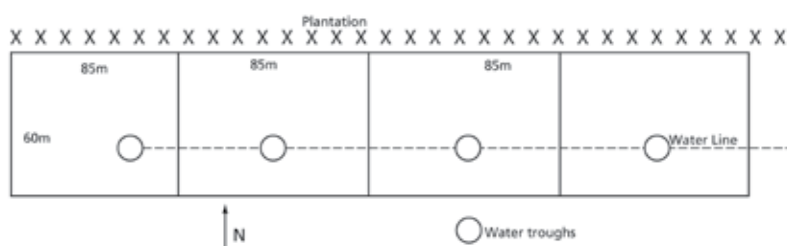

Removing the tail end can be easily done by eye through the draft process. There is no need to weigh or condition score sheep to do this well because the poor doers are obvious, particularly if in short wool.

Weighing and/or condition scoring a sample of the ewes is useful for monitoring mob performance and provides a means of adjusting rations when required.

CLASS OF SHEEP

It is usually easier to manage adult sheep rather than weaners in droughtlots, so if possible leave the weaners out on pasture. If it is necessary to confine weaners it can be done, but they are likely to need additional management. Weaners are also more susceptible to problems associated with disease.

TROUGHS

Troughs are not essential for successful management of sheep in droughtlots. Feeding directly onto the ground actually reduces the risk of deaths associated with smothering and poor doers in the mob (Graph 2).

One of the main advantages provided by troughs is to minimise feed wastage in wet weather so if not using troughs ensure you have a strategy to manage wet conditions. The most obvious way is

GRAPH 2: The effect of troughs on mortality rate

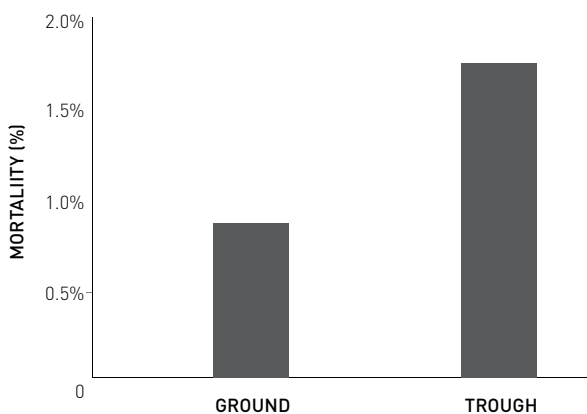

to let sheep out into a paddock for several days and feed them there until the droughtlot dries out.

FEEDING OF ROUGHAGE

Most departmental publications provide comprehensive information on the feed requirements of sheep and these should be referred to when calculating quantities to feed.

Research work done over 50 years ago showed that sheep can be successfully fed whole wheat diets and that there is no benefit in terms of sheep performance or survival from including roughage in the ration. This, combined with the relatively high cost of roughage, has been the basis for the recommendation to feed grain only rations to sheep during droughts.

However sheep producer experience, trial work done in South Australia, and analysis of survey results show that there is a benefit in including some roughage in the ration. The AWI survey of the 2002/03 drought showed that feeding roughage (hay, straw or silage) reduced death rates from an average of 1.34 per cent to 0.76 per cent (Graph 3).

During previous droughts in South Australia, research work showed that mobs fed grain only had no higher mortality rate but did have a greater proportion of sheep removed as poor doers.

GRAPH 3: Effect of roughage in diet on mortality

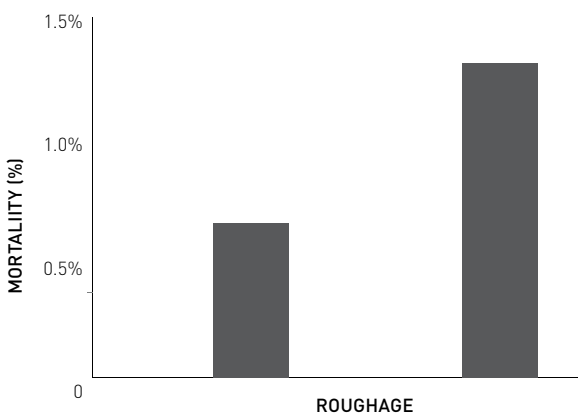

In addition the work showed that those mobs fed straw rather than hay had fewer poor doers (Table 6). Roughage should be fed at a minimum of 1kg/head/week.

Roughage does not need to be high quality and if only small quantities of roughage are to be fed, it is best to feed low quality roughage such as straw. This helps to ensure that all sheep in the mob have access to some roughage whereas high quality roughage is consumed rapidly by a small number of aggressive feeders.

ANIMAL HEALTH

In addition the work showed that those mobs fed straw rather than hay had fewer poor doers (Table 6). Roughage should be fed at a minimum of 1kg/head/week.

- Acidosis associated with high grain intakes of animals that are not accustomed to such rations. To minimise the risk, ensure animals are introduced to grain over the time recommended in state department publications. The schedule usually requires 3-4 weeks to build the ration up to that required for maintenance feeding. Some sheep producers experienced problems with acidosis towards the end of the scheduled introduction period when daily rations were increased from 430g/head/day up to 860g every second day. Producer experience has shown that there is less risk of acidosis if this increase is done with an extra step when sheep are fed 650g per head every second day.



Animal health problems in droughtlots tend to be concentrated on a few factors which can cause substantial health problems if not managed well ©CSIRO Plant Industry

TABLE6: Inclusion of roughage

	MINIMAL ROUGHAGE		MODERATE ROUGHAGE	
	HAY	STRAW	HAY	STRAW
QUANTITY (KG)	0.5	0.7	1.0	1.4
POOR DOERS (%)	25	8	18	3

Source: Brian Ashton and Alex King, PIRSA*

- Access to roughage is also important if sheep are being introduced to grain in the droughtlot rather than at pasture. If possible, sheep should always be introduced to full grain rations prior to introduction to the droughtlot to minimise the risk of acidosis and to identify as many shy feeders as possible.
- High levels of grain feeding predispose sheep to enterotoxaemia (pulpy kidney). To minimise this risk, sheep should have at least two vaccinations at least one month apart with the second at least two weeks prior to commencement of grain feeding. Young sheep are the most likely not to have had a complete vaccination history. Older sheep are likely to have had a number of clostridial vaccinations over their life so are more likely to have a higher level of immunity. A booster should still be given to overcome the higher risk that long periods of grain feeding present.
- Internal parasites can be a problem in droughtlots simply due to the high concentration of sheep. A drench prior to entry is worthwhile and worm burdens should be monitored by use of faecal egg counts, particularly in young sheep. Young sheep tend to present a higher risk.
- Some diseases are more likely in concentrated mobs. The two main risks are coccidiosis and salmonella infection in stressed or young sheep. Contaminated feed and water can be predisposing factors. If you have concerns at any stage, investigate problems as soon as they start to appear because high concentrations of sheep will encourage a rapid spread of any problems. Consult a veterinarian.

ANIMAL HEALTH

CASE STUDY 6

Case study 6 focuses largely on nutritional concerns. It outlines how one sheep producer managed problems with infection which arose in a mob of weaners during lotfeeding.

FARM PROFILE

Area: 1,417 hectares (3,500 acres).

Pastures: 90 per cent pasture improved (rye, sub-clover, phalaris, cocksfoot, fescues).

Maintenance level super applied to 100 per cent pasture each year for last 20 years.

Labour: One labour unit per 9,000-10,000 sheep.

Enterprise: Self replacing Merino flock

MANAGEMENT

Once the weaners had been introduced to the grain ration, they were moved into the first intensive droughtlot yard. Maiden ewes were still in the paddock and maintaining weight.

- The weaners were maintaining condition score and consuming 350g per day of the ration.
- The maiden ewes had a condition score of 2.5-3.0 across the flock.



The recommended three drenches for coccidiosis were administered on three successive days

Lambs were looking weak and began dying overnight. Given the rapid onset of the problem a solution had to be found quickly. A local vet confirmed coccidiosis and recommended that three drenches be administered on three successive days.

The infection was halted after intensive drenching.

There was a second outbreak 3-4 weeks later. To combat the second outbreak sheep were treated using a drench and move system at 3-5 day intervals. This program proved as successful as the one recommended by the vet.

The coccidiosis was attributed to stress at weaning, feeding off the ground in the introduction paddock and the intensity of the droughtlot situation. Having the ability to rotate through several pens was important to improve hygiene when sheep, particularly young sheep, are confined for long periods.

Worms were monitored closely for both mobs through the whole exercise. They indicated that no drench was necessary for the weaners or the maidens through the entire confinement.

The computer program GrazFeed, a decision support tool that helps calculate sheep and cattle feed requirements, was used to formulate the rations. It recommended a mix of 70% oats, 20% lupins, 10% hay and 1.0%-1.5% lime for the lambs. This proved to be accurate as the weaner condition score did not vary much over the five months but they did grow steadily. The maidens were fed the same mix as the weaners but adjusted up for their liveweight. This saved time on preparing rations.

Average feed cost per week for the weaners was \$0.87 and \$0.92 per week for the ewes.

Feeds were sourced on price and quality. Wheat and lucerne hay were available and used depending on value. Grains were kept more constant due to difficulty and inefficiency in random changes. Over time, various grains were blended into the ration including triticale, barley, and sheep nuts.

DEATHS

Some lambs were lost due to smothering whilst trying to access hay as it was deposited in the pen. Total lamb deaths were estimated at 7 per cent. Lambs were also lost in the pen with the dam in it.

Ewe mortality was low (<1 per cent) as they did not experience any significant disease problems. Few experienced any grain poisoning or feed related complications.

LESSONS LEARNT AND THINGS TO DO DIFFERENTLY NEXT TIME

Using a specialist nutritionist would be something considered next time. Greater use of specialist knowledge in sheep requirements and fine tuning the ration would have saved money.

HOW DOES LOT FEEDING DURING DROUGHT AFFECT WOOL QUALITY?

Confining sheep at high stocking rates in small areas can have a number of effects on wool quality. The experience of sheep producers has shown that there is considerable variation in the effect of droughtlots on wool quality. The main issues have been:

- Management of staple strength, particularly as sheep are introduced and released from the droughtlot. The key is to manage the change in nutrition as smoothly as possible. Moving sheep from the paddock to the droughtlot should be done as smoothly as possible with a gradual introduction of grain. Conversely, when releasing sheep, going from a maintenance ration in the droughtlot to high quality pastures, with for example 1,500kg dry matter/hectare, will result in rapid weight gain and a rapid change in the fibre diameter profile. Rapid changes in fibre profiles will result in reduced staple strength. The aim should be to ensure sheep go from a maintenance droughtlot ration to a maintenance pasture ration. Any increase above maintenance should be as gradual as possible.

- Low staple strength is not an inherent problem associated with droughtlots, rather it is about how sheep are managed into and out of the droughtlot that is important.
- High dust levels in some mobs. This was a particular problem with sheep going into droughtlots with long wool. Yields of 50 per cent or less were common in these situations. Extremely low yields will affect the clean price of wool, particularly when there is an increase in supply. Wherever possible, it is preferable to have sheep in short wool while they are confined. This is not always going to be possible because a premature shearing may be required which in turn may result in larger discounts than the dust in full length wool. Consider your options and do your sums carefully.



Confining sheep at high stocking rates in small areas can have a number of effects on wool quality

RELEASE OF SHEEP AFTER DROUGHT

Weaning sheep out of the droughtlot and back into the paddock is considered important to avoid any marked break in the wool. Some sheep producers have found it useful in the past to let sheep out onto feed for a few hours each day after feeding over a set period of weeks.

To reduce the likelihood and risk of digestive disturbances, it is recommended that sheep are released from droughtlot facilities after feeding. It is also necessary to continue with drought rations until pasture dry matter has reached sufficient quantities to meet the requirements of the sheep.

Late pregnant or lactating ewes should continue to be fed limestone and salt mix.

Delaying release will increase dry matter (DM) availability and provide optimum growth rates if pastures reach approximately 1,500kg of DM/hectare. In many situations, this is unlikely to be economic because at a growth rate of 50kg/hectare/day after the drought breaks, it will take 30 days to reach 1,500kg assuming zero decay.



Weaning sheep out of the droughtlot and back into the paddock is considered important to avoid any marked break in the wool.

TABLE6: Sheep producer reasons for using droughtlot

REASONS	PER CENT SURVEYED
PRESERVE SOIL / PASTURES	53
MORE CONVENIENT TO FEED / MANAGE	39
EASIER TO MANAGE WATER	6

In most instances the cost of maintaining sheep in the droughtlot will mean sheep are released well before pastures reach 1,500kg. Dry sheep being fed a maintenance ration in a droughtlot will continue to maintain liveweight on pasture with 400-500kg of DM/hectare.

SHEEP PRODUCER COMMENTS

Of those surveyed, 98 per cent said that they would use a droughtlot again if the situation demanded it. The main reasons are given in Table 7.

Other general sheep producer comments included:

- Weaners are more difficult to manage.
- Roughage appeared to be important.
- Dust is a problem.
- Do not need purpose built facility.
- Hard on stock and not a good experience but prepared to do it again because the alternative is worse.

This publication has been printed on ecoStar paper



ISO
14001



100%



PCF
process
chlorine free



paper
made
carbon
neutral

ecoStar is an environmentally responsible paper made Carbon Neutral. The greenhouse gas emissions of the manufacturing process including transportation of the finished product to BJ Ball Papers Warehouses has been measured by the Edinburgh Centre for Carbon Neutral Company and the fibre sourced has been independently certified by the Forest Stewardship Council (FSC). ecoStar is manufactured from 100% Post Consumer Recycled paper in a Process Chlorine Free environment under the ISO 14001 environmental management system.

AWI has a range of drought planning, management and recovery resources available for sheep producers going into, enduring and recovering from drought. For your free copies, visit www.wool.com/publications or call the AWI Helpline on 1800 070 099.



Managing Fodder Prices for Droughts:

A guide which focuses on strategies to help sheep producers manage fodder prices and supply risks during droughts.



Which Sheep Do I Keep?

A guide to help sheep producers decide which sheep to keep during drought. The guide helps managers, when confronted with a pasture shortage, determine whether to sell or supplementary feed all, some or none of their flock.



Stock Water - a Limited Resource:

Calculate stock water budgets - critical information for any sheep producers considering drought lotting their sheep.



WOOL.COM